

Made to measure

OPERATING INSTRUCTIONS AND
SYSTEM DESCRIPTION FOR THE

ION-01M

**IONSENSITIVE AMPLIFIER
MODULE FOR EPMS SYSTEMS**



VERSION 1.5
npi 2019

Table of Contents

1. Safety Regulations	3
2. EPMS-07 Modular Plug-In System	4
2.1. General System Description / Operation	4
2.2. EPMS-07 Housing	4
2.3. EPMS-H-07 Housing	4
2.4. EPMS-E-07 Housing	4
2.5. EPMS-03	5
2.6. PWR-03D	5
2.7. System Grounding	6
2.8. Technical Data	6
3. ION-01M	7
3.1. Components of the ION-01M	7
3.2. System Description	7
3.3. Description of the Front Panel and Operation	8
3.4. Headstage	11
3.5. Test resistors	11
3.6. Electrode connection	12
4. Literature	13
5. Technical Data	13

1. Safety Regulations

VERY IMPORTANT: Instruments and components supplied by npi electronic are NOT intended for clinical use or medical purposes (e.g. for diagnosis or treatment of humans), or for any other life-supporting system. npi electronic disclaims any warranties for such purpose. Equipment supplied by npi electronic must be operated only by selected, trained and adequately instructed personnel. For details please consult the GENERAL TERMS OF DELIVERY AND CONDITIONS OF BUSINESS of npi electronic, D-71732 Tamm, Germany.

- 1) **GENERAL:** This system is designed for use in scientific laboratories and must be operated by trained staff only. General safety regulations for operating electrical devices should be followed.
- 2) **AC MAINS CONNECTION:** While working with the npi systems, always adhere to the appropriate safety measures for handling electronic devices. Before using any device please read manuals and instructions carefully.
The device is to be operated only at 115/230 Volt 60/50 Hz AC. Please check for appropriate line voltage before connecting any system to mains.
Always use a three-wire line cord and a mains power-plug with a protection contact connected to ground (protective earth).
Before opening the cabinet, unplug the instrument.
Unplug the instrument when replacing the fuse or changing line voltage. Replace fuse only with an appropriate specified type.
- 3) **STATIC ELECTRICITY:** Electronic equipment is sensitive to static discharges. Some devices such as sensor inputs are equipped with very sensitive FET amplifiers, which can be damaged by electrostatic charge and must therefore be handled with care. Electrostatic discharge can be avoided by touching a grounded metal surface when changing or adjusting sensors. **Always turn power off when adding or removing modules, connecting or disconnecting sensors, headstages or other components from the instrument or 19" cabinet.**
- 4) **TEMPERATURE DRIFT / WARM-UP TIME:** All analog electronic systems are sensitive to temperature changes. Therefore, all electronic instruments containing analog circuits should be used only in a warmed-up condition (i.e. after internal temperature has reached steady-state values). In most cases a warm-up period of 20-30 minutes is sufficient.
- 5) **HANDLING:** Please protect the device from moisture, heat, radiation and corrosive chemicals.

2. EPMS-07 Modular Plug-In System

2.1. General System Description / Operation

The npI EPMS-07 is a modular system for processing of bioelectrical signals in electrophysiology. The system is housed in a 19" rackmount cabinet (3U) has room for up to 7 plug-in units. The plug-in units are connected to power by a bus at the rear panel.

The plug-in units must be kept in position by four screws (M 2,5 x 10). The screws are important not only for mechanical stability but also for proper electrical connection to the system housing. Free area must be protected with covers.

2.2. EPMS-07 Housing

The following items are shipped with the EPMS-07 housing:

- ✓ EPMS-07 cabinet with built-in power supply
- ✓ Mains cord
- ✓ Fuse 2 A / 1 A, slow (inserted)
- ✓ Front covers

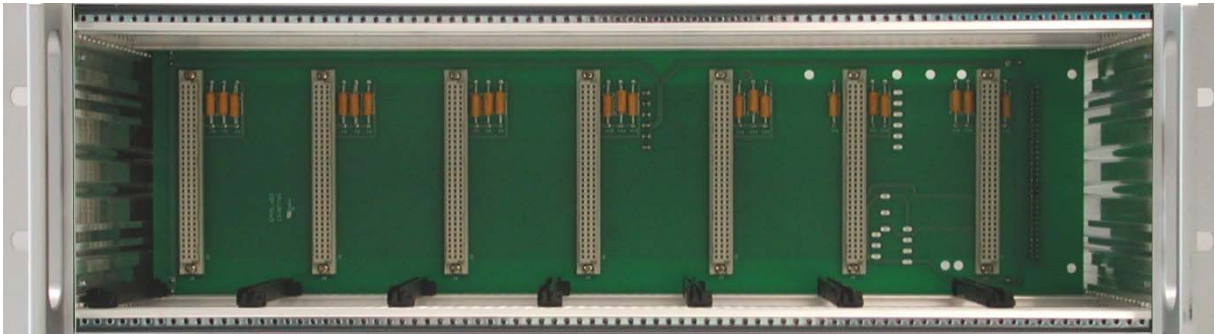

Figure 1: Left: front view of empty EPMS-07 housing.

In order to avoid induction of electromagnetic noise the power supply unit, the power switch and the fuse are located at the rear of the housing (see Figure 2, right).

2.3. EPMS-H-07 Housing

In addition to the standard power supply of the EPMS-07, the EPMS-H-07 has a built-in high voltage power supply. This is necessary for all MVCS / MVCC modules, the HVA-100, HV-TR150 and HVC-03M modules. The output voltage depends on the modules in use.

2.4. EPMS-E-07 Housing

The following items are shipped with the EPMS-E-07 housing:

- ✓ EPMS-E-07 cabinet
- ✓ External Power supply PWR-03D
- ✓ Power cord (PWR-03D to EPMS-E-07)
- ✓ Mains chord
- ✓ Fuse 1.6 A / 0.8 A, slow (inserted)
- ✓ Front covers

The EPMS-E-07 housing is designed for low-noise operation, especially for extracellular and multi channel amplifiers with plugged in filters. It operates with an external power supply to minimize distortions of the signals caused by the power supply.

2.5. EPMS-03

The following items are shipped with the EPMS-07 housing:

- ✓ EPMS-07 cabinet with built-in power supply
- ✓ Mains cord
- ✓ Fuse 0,4 A / 0,2 A, slow (inserted)
- ✓ Front covers



Figure 2: Left: front view of EPMS-03 housing. Right: rear panel detail of EPMS-03 and EPMS-07 housing.

In order to avoid induction of electromagnetic noise the power supply unit, the power switch and the fuse are located at the rear of the housing (see Figure 2, right).

2.6. PWR-03D

The external power supply PWR-03D is capable of driving up to 3 EPMS-E housings. Each housing is connected by a 6-pole cable from one of three connectors on the front panel of the PWR-03D to the rear panel of the respective EPMS-E housing. (see Figure 3, Figure 4). A POWER LED indicates that the PWR-03D is powered on (see Figure 3, left). Power switch, voltage selector and fuse are located at the rear panel (see Figure 3, right).

Note: The chassis of the PWR-03D is connected to protective earth, and it provides protective earth to the EPMS-E housing if connected.



Figure 3: Left: PWR-03D front panel view Right: PWR-03D rear panel view.

Note: This power supply is intended to be used with npi EPMS-E systems only.

2.7. System Grounding

EPMS-07/EPMS-03

The 19" cabinet is grounded by the power cable through the ground pin of the mains connector (= protective earth). In order to avoid ground loops the internal ground is isolated from the protective earth. The internal ground is used on the BNC connectors or GROUND plugs of the modules that are inserted into the EPMS-07 housing. The internal ground and mains ground (= protective earth) can be connected by a wire using the ground plugs on the rear panel of the instrument. It is not possible to predict whether measurements will be less or more noisy with the internal ground and mains ground connected. We recommend that you try both arrangements to determine the best configuration.

EPMS-E-07



The 19" cabinet is connected to the CHASSIS connector at the rear panel. It can be connected to the SYSTEM GROUND (SIGNAL GROUND) on the rear panel of the instrument (see Figure 4).

The chassis can be linked to PROTECTIVE EARTH by connecting it to the PWR-03D with the supplied 6-pole cable **and** by interconnecting the GROUND and PROTECTIVE EARTH connectors on the rear panel of the PWR-03D (see Figure 3). Best performance is generally achieved without connection of the chassis to protective earth.

Important: Always adhere to the appropriate safety measures.

Figure 4: Rear panel connectors of the EPMS-E-07

2.8. Technical Data

EPMS-07, EPMS-E-07 and EPMS-H-07

19" rackmount cabinet, for up to 7 plug-in units

Dimensions: 3U high (1U=1 3/4" = 44.45 mm), 254 mm deep

EPMS-07 and EPMS-H-07

Power supply: 115/230 V AC, 60/50 Hz, fuse 2 A / 1 A slow, 45-60 W

EPMS-E-07

External power supply (PWR-03D) 115/230 V AC, 60/50 Hz, fuse 1.6/0.8 A, slow

Dimensions of external power supply: (W x D x H) 247 mm x 180 mm x 90 mm

EPMS-03

Power supply: 115/230 V AC, 60/50 Hz, fuse 0.4 A / 0.2 A slow

Maximum current supply: 500 mA

Dimensions: 3U high (1U=1 3/4" = 44.45 mm), 245 mm deep, 265 mm wide

3. ION-01M

3.1. Components of the ION-01M

The following items are shipped with the ION-1M system:

- ✓ Differential headstage with Teflon connectors
- ✓ Ground connector (2.4 mm banana plug)
- ✓ Electrode connectors (1.0 mm banana plugs)
- ✓ Manual

3.2. System Description

The ION-01M amplifier is a plug-in unit for the npI EPMS-07 modular system. It was designed for recording signals from ionsensitive microelectrodes.

The system consists of a main amplifier system and a small headstage with differential input. It can be used in all kind of preparations e.g. single cells, slices or in *in vivo* preparations. It has a low-noise high common mode rejection (CMR) differential input equipped with ultra-low bias amplifiers (fA range). The OUTPUT has two gains selectable by a toggle switch (x10 or x100). Both inputs (S: sample or signal, R: reference) have a capacity and OFFSET compensation. The reference input can also be filtered to improve AC CMR.

Warning: Both headstage inputs are very sensitive to static discharges and can be damaged by electrostatic charge, and must therefore be handled with care. Touching a grounded metal surface when changing or adjusting electrodes can avoid electrostatic discharge. **Always turn power off when connecting or disconnecting the headstage from the instrument.**

3.3. Description of the Front Panel and Operation

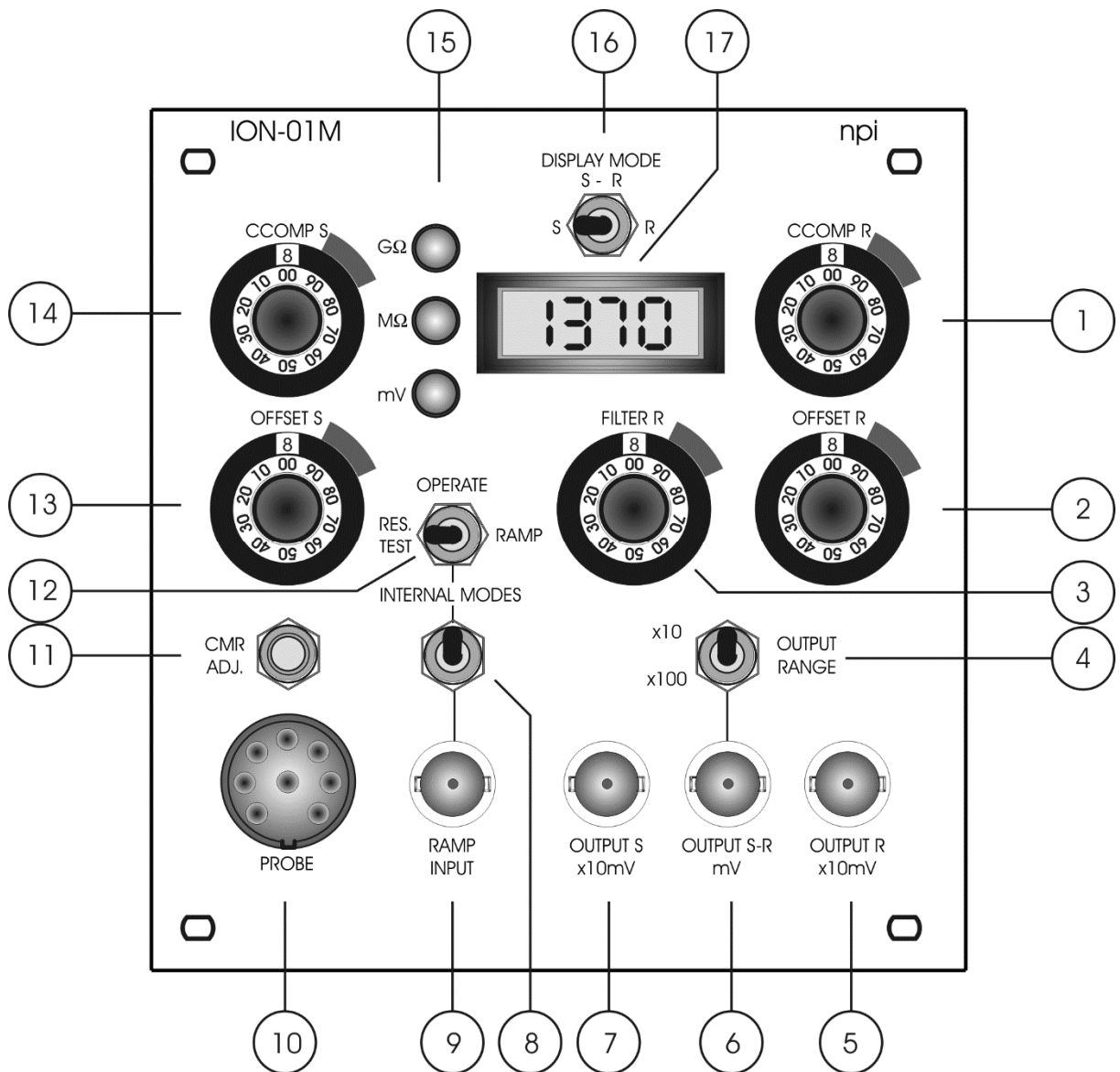

Figure 5: Front panel view of the ION-1M

In the following description of the front panel elements each element has a number that is related to that in Figure 5. The number is followed by the name (in uppercase letters) written on the front panel and the type of the element (in lowercase letters). Then, a short description of the element is given.

(1) CCOMP R potentiometer

10-turn potentiometer for setting the capacity compensation for the reference electrode.

(2) OFFSET R potentiometer

10-turn potentiometer for setting the OFFSET compensation for the reference electrode; range: ± 100 mV.

(3) FILTER R potentiometer

10-turn potentiometer for setting the low pass FILTER for the reference electrode. The low pass filter improves AC CMR; range: 100 Hz...10 kHz.

(4) OUTPUT RANGE switch

Switch for setting the range (x10 or x100) of the OUTPUT of the S-R signal.

(5) OUTPUT R connector

BNC connector providing the voltage at the reference electrode amplified by ten mV.

(6) OUTPUT S-R connector

BNC connector providing the voltage at the sample electrode minus the signal at the reference electrode. The amplification factor is set by #4.

(7) OUTPUT S connector

BNC connector providing the voltage at the sample (signal) electrode amplified by ten mV.

(8) INTERNAL MODES switch

Switch for selecting the RAMP INPUT BNC connector #9 or the OPERATE switch #12.

(9) RAMP INPUT connector

BNC connector for connecting a ramp (± 10 V max.) for measuring the electrode resistance. The ramp signal is fed into a capacitor, differentiated and generates a rectangular signal at the electrode resistance. This signal is provided at the OUTPUT S connector, and its amplitude is proportional to the electrode resistance.

(10) PROBE connector

Connector for connecting the headstage.

(11) CMR ADJ. trimpot

Trimpot for adjusting the CMR. CMR is adjusted by linking the same rectangular signal to both inputs S and R, watching the OUTPUT S-R and turning the trimpot until no signal can be seen at the oscilloscope.

(12) OPERATE switch

Switch for selecting an internal generated ramp (1.5 V / s) for electrode resistance testing (see also #9) or for showing the electrode resistance at display #17. The electrode to be tested is selected by switch #16.

(13) OFFSET S potentiometer

10-turn potentiometer for setting the OFFSET compensation for the sample electrode; range: ± 100 mV.

(14) CCOMP S potentiometer

10-turn potentiometer for setting the capacity compensation for the sample electrode.

(15) GΩ / MΩ / mV LEDs

LEDs indicating the unit of display #17.

(16) DISPLAY MODE switch

Switch for selecting the electrode whose signal that is displayed at #17 (voltage or resistance)

S: Voltage at the sample electrode or resistance of the sample electrode

S-R: Signal at the sample electrode minus signal at the reference electrode

R: Voltage at the reference electrode or resistance of the reference electrode.

Hint: If electrode resistance test is selected and the switch is in S-R position, the voltage difference S-R is shown anyway and the GΩ / MΩ / mV LEDs are switched off!

(17) Digital display

Display showing the voltage selected by switch #16 or the resistance of the sample electrode or the resistance of the reference electrode. XXX.X mV or XX.XX GΩ (sample electrode) or XXX.X MΩ (reference electrode).

3.4. Headstage

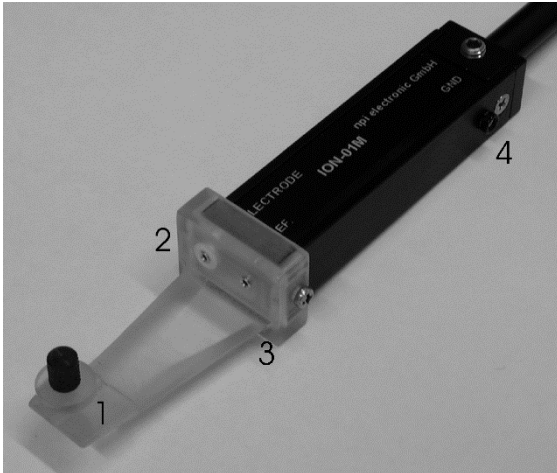

Figure 6: headstage

- 1: electrode mount
- 2: connector for the sample (ionsensitive) electrode, S
- 3: connector for the reference electrode (1 mm jack), R
- 4: connector for ground, GND

3.5. Test resistors

Two resistors are provided to test the amplifier. Both inputs can be connected to a function generator via a voltage divider (/1000) which is also supplied.

For testing and CMR adjustment apply a rectangular signal (e.g. 2 V) to the voltage divider. This way, identical, small signal will be applied to both inputs, and by adjusting filters, capacity compensations and CMR an ideally straight signal will appear at OUTPUT S-R.

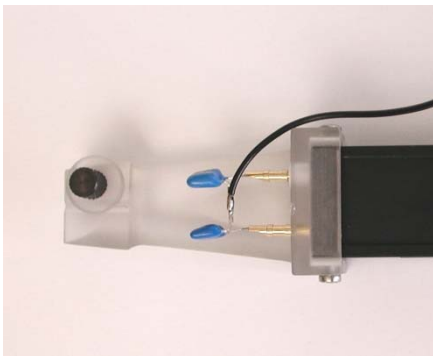

Figure 7: headstage resistors

Test resistor for sample electrode: 1 G Ω

Test resistor for reference electrode: 10 M Ω

Note: Connection of these resistors to ground protects the inputs from damage by electrostatic discharge.

3.6. Electrode connection

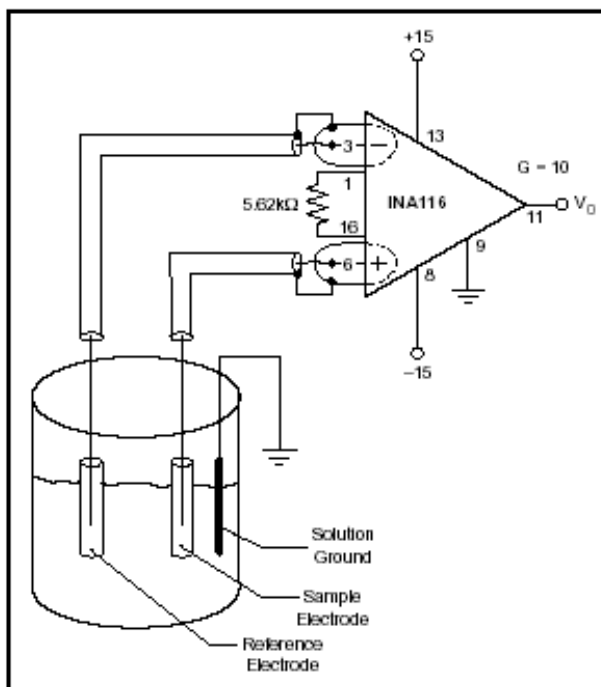

Figure 8: Equivalent circuit of ion-sensitive measurement

The principle of operation is shown in Figure 8. Two electrodes, an “active” ion exchanger sample electrode (+) and a reference electrode (-), which are connected to high impedance buffers (input resistance better than $10^{15} \Omega$) in the headstage, are required for detecting signals from ion sensitive electrodes. In addition the bath surrounding the cell must have a ground connection (AgAgCl pellet or Agar bridge, see Figure 8). It is important that there is always this pathway to ground although the bias current is in the fA range, to avoid saturation effects. The electrodes can be connected by thin flexible unshielded wires (e.g. inside a Faraday cage) to the headstage.

Important: The headstage inputs are very sensitive and can be damaged by electrostatic charge. Therefore be handled with great care. Touching a grounded metal surface when changing or adjusting electrodes can avoid electrostatic discharge.

The wanted signal is available at the S-R connector and can be amplified by 10 or by 100.



ELECTROSTATIC DISCHARGE SENSITIVITY

This integrated circuit can be damaged by ESD. Burr-Brown recommends that all integrated circuits be handled with appropriate precautions. Failure to observe proper handling and installation procedures can cause damage.

ESD damage can range from subtle performance degradation to complete device failure. Precision integrated circuits may be more susceptible to damage because very small parametric changes could cause the device not to meet its published specifications.

4. Literature

- ❑ Polder, H.R., M. Weskamp, K. Linz and R. Meyer **Voltage-Clamp and Patch-Clamp Techniques**, Chapter 3.4, pp. 272-323 in Dhein, St.; Mohr, F.W.; Delmar, M. (Eds.) **Practical Methods in Cardiovascular Research**, Springer Heidelberg 2004
- ❑ Schwarz, W. and J. Rettinger (2003) **Foundations of Electrophysiology** Second Edition, Shaker Verlag Aachen, 2003
- ❑ Voipio, J., M. Pasternack and K. Macleod (1996) **Ion-sensitive microelectrodes**, Chapter 11 in Ogden, D (ed.) (1996) **Microelectrode Techniques - The Plymouth Workshop Handbook**, Second Edition, The Company of Biologists Ltd., Cambridge.

5. Technical Data

ION-01M

Input range:	±1000 mV
Input impedance:	>10 TΩ, related to ground
Differential input:	cmr >120 dB @ gain 100
FILTER	
(reference electrode)	1-pole low-pass, range: 100 Hz...10 kHz
GAIN (S-R):	x10, x100, selected by toggle switch
OFFSET compensation:	range: ±100 mV
CAPACITANCE compensation:	range: 0-30 pF
Output:	range: ±12 V into 1 kΩ / ±1 V into 50 Ω
Digital display:	XXX.X mV or XX.XX GΩ (sample electrode) or XXX.X MΩ (reference electrode)
Size:	front panel 12 HP (60.6 mm) x 3U (128,5 mm), 7" (175 mm) deep