

# OPERATING INSTRUCTIONS AND SYSTEM DESCRIPTION FOR THE

## BF-48DGX

# DIFFERENTIAL AMPLIFIER / FILTER MODULE FOR EPMS SYSTEMS



VERSION 2.5

npi 2023

---

## Table of Contents

1. Safety Regulations.....	3
2. EPMS-07 Modular Plug-In System.....	4
2.1. General System Description / Operation.....	4
2.2. EPMS-07 Housing.....	4
2.3. EPMS-H-07 Housing.....	4
2.4. EPMS-E-07 Housing.....	4
2.5. EPMS-03.....	5
2.6. PWR-03D.....	5
2.7. System Grounding.....	6
EPMS-07/EPMS-03.....	6
EPMS-E-07.....	6
2.8. Technical Data.....	6
EPMS-07, EPMS-E-07 and EPMS-H-07.....	6
EPMS-07 and EPMS-H-07.....	6
EPMS-E-07.....	6
EPMS-03.....	6
3. BF-48DGX Differential Amplifier / Filter Module.....	7
3.1. BF-48DGX Components.....	7
3.2. BF-48DGX System Description.....	7
3.3. Signal Flow Diagram.....	7
3.4. Description of the Front Panel.....	8
4. Literature.....	12
5. Technical Data.....	13

## 1. Safety Regulations

**VERY IMPORTANT: Instruments and components supplied by npi electronic are NOT intended for clinical use or medical purposes (e.g. for diagnosis or treatment of humans), or for any other life-supporting system. npi electronic disclaims any warranties for such purpose. Equipment supplied by npi electronic must be operated only by selected, trained and adequately instructed personnel. For details please consult the GENERAL TERMS OF DELIVERY AND CONDITIONS OF BUSINESS of npi electronic, D-71732 Tamm, Germany.**

- 1) **GENERAL:** This system is designed for use in scientific laboratories and must be operated only by trained staff. General safety regulations for operating electrical devices should be followed.
- 2) **AC MAINS CONNECTION:** While working with the npi systems, always adhere to the appropriate safety measures for handling electronic devices. Before using any device please read manuals and instructions carefully.  
The device is to be operated only at 115/230 Volt 60/50 Hz AC. Please check for appropriate line voltage before connecting any system to mains.  
Always use a three-wire line cord and a mains power-plug with a protection contact connected to ground (protective earth).  
Before opening the cabinet, unplug the instrument.  
Unplug the instrument when replacing the fuse or changing line voltage. Replace fuse only with an appropriate specified type.
- 3) **STATIC ELECTRICITY:** Electronic equipment is sensitive to static discharges. Some devices such as sensor inputs are equipped with very sensitive FET amplifiers, which can be damaged by electrostatic charge and must therefore be handled with care. Electrostatic discharge can be avoided by touching a grounded metal surface when changing or adjusting sensors. **Always turn power off when adding or removing modules, connecting or disconnecting sensors, headstages or other components from the instrument or 19" cabinet.**
- 4) **TEMPERATURE DRIFT / WARM-UP TIME:** All analog electronic systems are sensitive to temperature changes. Therefore, all electronic instruments containing analog circuits should be used only in a warmed-up condition (i.e. after internal temperature has reached steady-state values). In most cases a warm-up period of 20-30 minutes is sufficient.
- 5) **HANDLING:** Please protect the device from moisture, heat, radiation and corrosive chemicals.

## 2. EPMS-07 Modular Plug-In System

### 2.1. General System Description / Operation

The npI EPMS-07 is a modular system for processing of bioelectrical signals in electrophysiology. The system is housed in a 19" rackmount cabinet (3U) has room for up to 7 plug-in units. The plug-in units are connected to power by a bus at the rear panel.

The plug-in units must be kept in position by four screws (M 2,5 x 10). The screws are important not only for mechanical stability but also for proper electrical connection to the system housing. Free area must be protected with covers.

### 2.2. EPMS-07 Housing

The following items are shipped with the EPMS-07 housing:

- 3 EPMS-07 cabinet with built-in power supply
- 3 Mains cord
- 3 Fuse 2 A / 1 A, slow (inserted)
- 3 Front covers

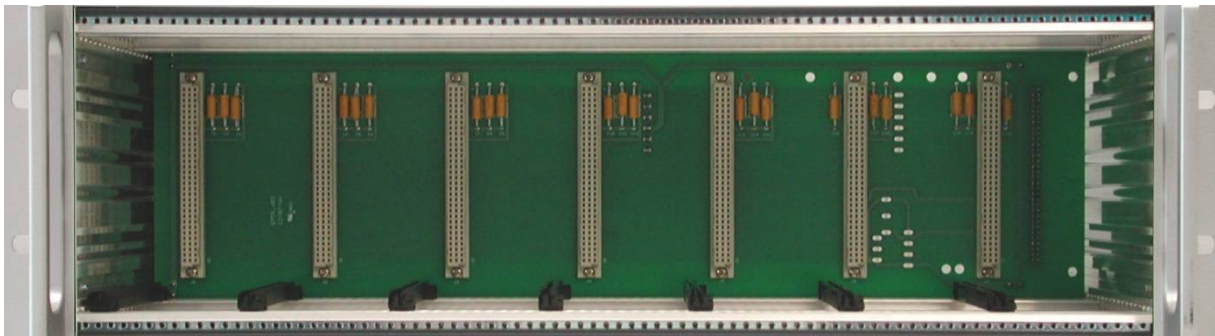

Figure 1: Left: front view of empty EPMS-07 housing.

In order to avoid induction of electromagnetic noise the power supply unit, the power switch and the fuse are located at the rear of the housing (see Figure 2, right).

### 2.3. EPMS-H-07 Housing

In addition to the standard power supply of the EPMS-07, the EPMS-H-07 has a built-in high voltage power supply. This is necessary for all MVCS / MVCC modules, the HVA-100, HV-TR150 and HVC-03M modules. The output voltage depends on the modules in use.

### 2.4. EPMS-E-07 Housing

The following items are shipped with the EPMS-E-07 housing:

- 3 EPMS-E-07 cabinet
- 3 External Power supply PWR-03D
- 3 Power cord (PWR-03D to EPMS-E-07)
- 3 Mains chord
- 3 Fuse 1.6 A / 0.8 A, slow (inserted)
- 3 Front covers

The EPMS-E-07 housing is designed for low-noise operation, especially for extracellular and multi channel amplifiers with plugged in filters. It operates with an external power supply to minimize distortions of the signals caused by the power supply.

## 2.5. EPMS-03

The following items are shipped with the EPMS-07 housing:

- 3 EPMS-07 cabinet with built-in power supply
- 3 Mains cord
- 3 Fuse 0,4 A / 0,2 A, slow (inserted)
- 3 Front covers



Figure 2: Left: front view of EPMS-03 housing. Right: rear panel detail of EPMS-03 and EPMS-07 housing.

In order to avoid induction of electromagnetic noise the power supply unit, the power switch and the fuse are located at the rear of the housing (see Figure 2, right).

## 2.6. PWR-03D

The external power supply PWR-03D is capable of driving up to 3 EPMS-E housings. Each housing is connected by a 6-pole cable from one of three connectors on the front panel of the PWR-03D to the rear panel of the respective EPMS-E housing. (see Figure 3, Figure 4). A POWER LED indicates that the PWR-03D is powered on (see Figure 3, left). Power switch, voltage selector and fuse are located at the rear panel (see Figure 3, right).

**Note:** The chassis of the PWR-03D is connected to protective earth, and it provides protective earth to the EPMS-E housing if connected.

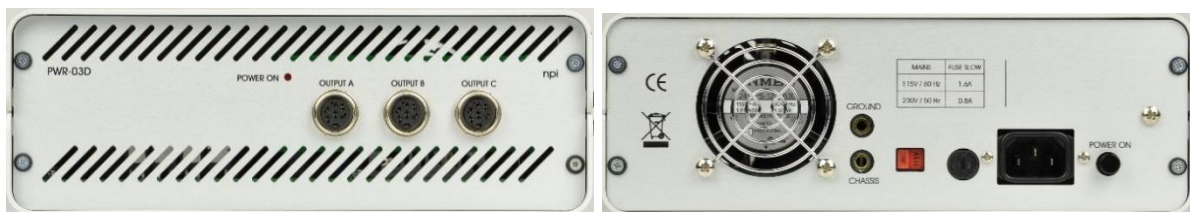

Figure 3: Left: PWR-03D front panel view      Right: PWR-03D rear panel view.

**Note:** This power supply is intended to be used with npi EPMS-E systems only.

## 2.7. System Grounding

### EPMS-07/EPMS-03

The 19" cabinet is grounded by the power cable through the ground pin of the mains connector (= protective earth). In order to avoid ground loops the internal ground is isolated from the protective earth. The internal ground is used on the BNC connectors or GROUND plugs of the modules that are inserted into the EPMS-07 housing. The internal ground and mains ground (= protective earth) can be connected by a wire using the ground plugs on the rear panel of the instrument. It is not possible to predict whether measurements will be less or more noisy with the internal ground and mains ground connected. We recommend that you try both arrangements to determine the best configuration.

### EPMS-E-07



The 19" cabinet is connected to the CHASSIS connector at the rear panel. It can be connected to the SYSTEM GROUND (SIGNAL GROUND) on the rear panel of the instrument (see Figure 4).

The chassis can be linked to PROTECTIVE EARTH by connecting it to the PWR-03D with the supplied 6-pole cable **and** by interconnecting the GROUND and PROTECTIVE EARTH connectors on the rear panel of the PWR-03D (see Figure 3). Best performance is generally achieved without connection of the chassis to protective earth.

**Important:** Always adhere to the appropriate safety measures.

Figure 4: Rear panel connectors of the EPMS-E-07

## 2.8. Technical Data

### EPMS-07, EPMS-E-07 and EPMS-H-07

19" rackmount cabinet, for up to 7 plug-in units

Dimensions: 19" (483 mm) wide, 10" (254 mm) deep, 5.25" (133 mm) high

### EPMS-07 and EPMS-H-07

Power supply: 115/230 V AC, 60/50 Hz, fuse 2 A / 1 A slow, 45-60 W

### EPMS-E-07

External power supply (PWR-03D) 115/230 V AC, 60/50 Hz, fuse 1.6/0.8 A, slow

Dimensions of external power supply:

9.7" (247 mm) wide, 7.1" (180 mm) deep, 3.55" (90 mm) high

### EPMS-03

Power supply: 115/230 V AC, 60/50 Hz, fuse 0.4 A / 0.2 A slow

Max. current supply: 500 mA

Dimensions: 10.4" (265 mm) wide, 9.65" (245 mm) deep, 5.25" (133 mm) high

### 3. BF-48DGX Differential Amplifier / Filter Module

#### 3.1. BF-48DGX Components

The following items are shipped with the BF-48DGX system:

- Amplifier / Filter module for the EPMS-07 system
- User manual

#### 3.2. BF-48DGX System Description

The BF-48DGX differential amplifier / filter is a plug-in unit for the npI EPMS-07 modular system. The BF-48DGX is designed to amplify and filter small bio-electrical signals. The input voltage range is  $\pm 12$  V. Two overload-LEDs indicate if the linear region of the amplifier is exceeded. All inputs and the output are BNC-connectors.

The INPUT impedance is  $1\text{ M}\Omega$  (other values possible). Using the differential INPUT configuration common mode signals and noise are removed allowing processing of signals with small amplitudes. The INPUT stage is followed by the offset compensation.

**Important:** To avoid noise interference the respective INPUT toggle switch should be in the zero position if one of the inputs is not used.

DC offsets can be compensated either by using the OFFSET control or by using the AC position of the input switches or by using the HIGHPASS FILTER. The BALANCE monitor allows fine tuning of DC offsets in the range of  $\pm 30$  mV. Three OFFSET ranges can be selected.

Optionally, a NOTCH filter can be used to eliminate 50 Hz or 60 Hz noise, respectively. The NOTCH filter can be bypassed with a toggle switch. See type label on the rear panel for the type of NOTCH filter installed in the purchased version of the BF-48DGX.

The BF-48DGX is equipped with a one-pole Bessel HIGHPASS FILTER. The filter has 15 corner frequencies (0.1 Hz - 3 kHz), a DC position, and can be bypassed.

The GAIN stage allows the amplification of the input signal from 1 to 1000. Gain is selected by a ten position rotary switch.

An output filter is applied to the amplified signal. The filter is an eight-pole Bessel LOWPASS FILTER and has 16 corner frequencies (20 Hz - 20 kHz). The filter can also be bypassed.

The position of the GAIN switch and of the FILTER switch(es) can be read from the respective monitor outputs (1 V / step).

#### 3.3. Signal Flow Diagram

The signal is passed through the BF-48DGX as shown below.

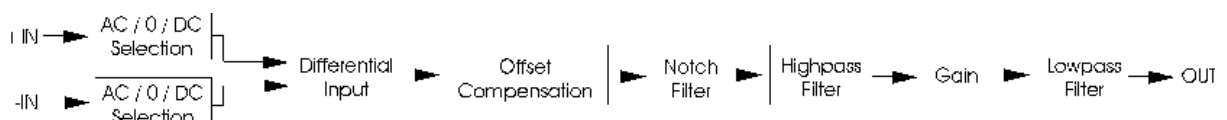



**3.4. Description of the Front Panel**

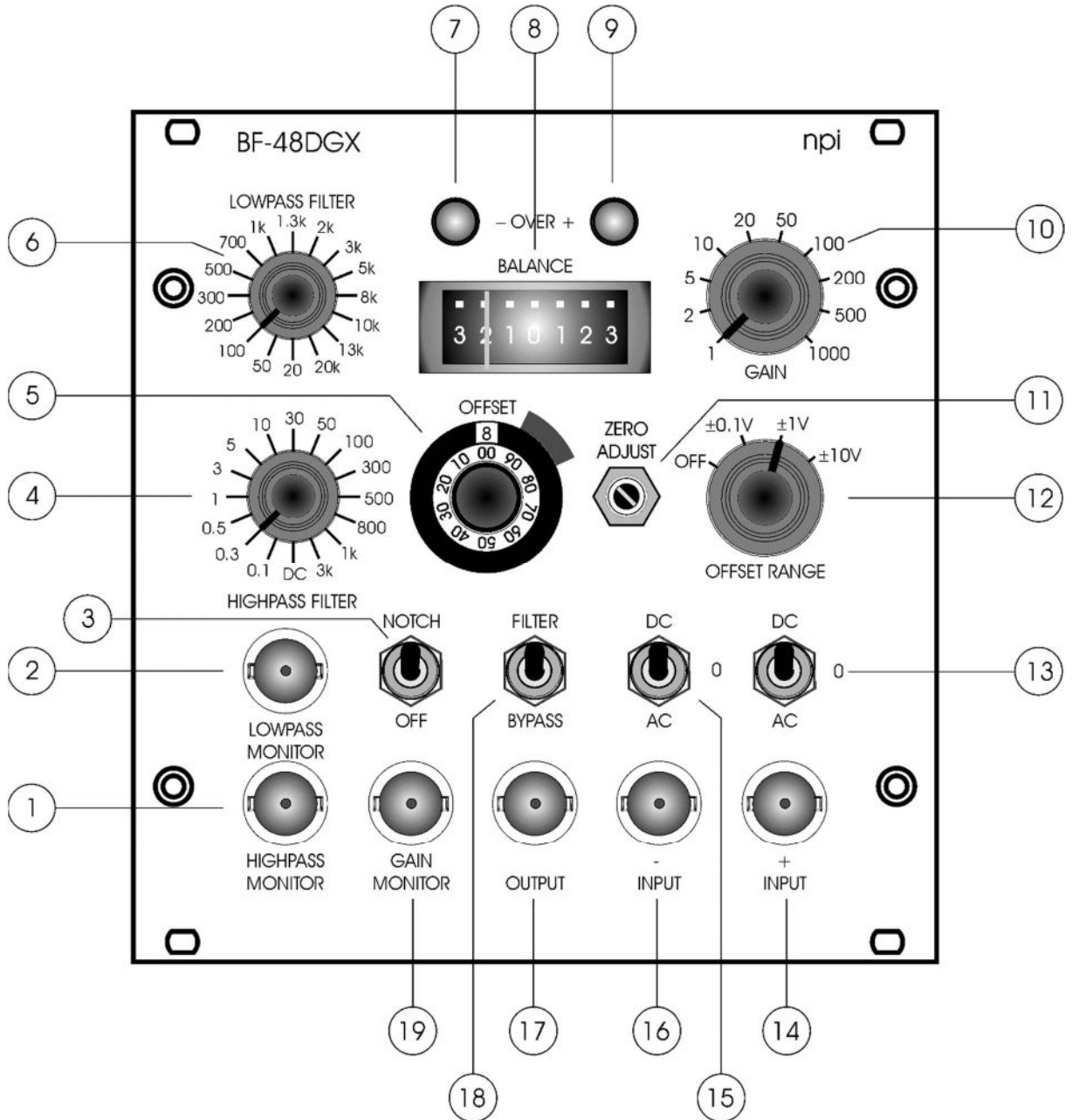

Figure 5: BF-48DGX front panel view



In the following description of the front panel elements each element has a number that is related to that in Figure 5. The number is followed by the name (in uppercase letters) written on the front panel and the type of the element (in lowercase letters). Then, a short description of the element is given.

(1) HIGHPASS MONITOR connector



BNC connector monitoring the position of the HIGHPASS FILTER (-8...+7 V, 1 V / step, OFF/DC = -8 V).

(2) LOWPASS MONITOR connector



BNC connector monitoring the position of the LOWPASS FILTER (-8...+7 V, 1 V / step).

(3) NOTCH switch (optional)



Switch to set the NOTCH filter (50 Hz / 60 Hz) or to bypass the NOTCH filter (switch position OFF).

(4) HIGHPASS FILTER switch



16 position rotary switch for selecting the corner frequency of the HIGHPASS FILTER (range: 0.1 Hz to 3 kHz). In DC position the HIGHPASS FILTER is bypassed.

**Important:** If the HIGHPASS FILTER is used the OFFSET control is disabled.

(5) OFFSET potentiometer



10 turn potentiometer to compensate for the OFFSET of a DC signal. The OFFSET range is set by a switch (12).

**Note:** Position 5.0 of the OFFSET control corresponds to 0 mV offset. The offset compensation only works if the input coupling switch (13, 15) is set to DC and the HIGHPASS FILTER is set to OFF.

(6) LOWPASS FILTER switch



16 position rotary switch for selecting the corner frequency of the LOWPASS FILTER (range: 20 Hz to 20 kHz). The LOWPASS FILTER can be bypassed using switch (18).

(7) (9) +/- OVER LEDs

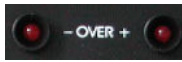

LEDs that indicate if the amplifier is 10% below its positive or negative limit ( $\pm 10$  V). The linear range of the amplifier is  $\pm 12$  V.

(8) BALANCE monitor



The analog monitor that displays the offset in the range of  $\pm 300$  mV for optimal cancellation of the OFFSET.

(10) GAIN switch



10 position rotary switch to set the amplification factor of the incoming signal (range: 1 to 1000).

(11) ZERO ADJUST potentiometer



Use this potentiometer to adjust the output offset while applying high gain.

(12) OFFSET RANGE switch



4 position rotary switch to set the range of the OFFSET potentiometer (5) (OFF,  $\pm 0.1$  V,  $\pm 1$  V,  $\pm 10$  V).

(13, 15) DC / 0 / AC switch

The position of the input coupling switch decides how the input signal is coupled:

AC: the input signal is AC coupled with a corner frequency of 0.1 Hz

DC: the input signal is DC coupled

0: the input signal is grounded



Switch to select the coupling of an incoming signal (AC or DC). Position 0 links the respective INPUT connector (14, 16) to ground.

(14, 16) INPUT connectors



BNC connectors to connect the signal to be processed. The INPUTs can be used in single-ended or differential configuration. In differential configuration the signal that is connected to -INPUT is subtracted from the signal that is connected to +INPUT.



**Important:** If only one INPUT is used (single-ended configuration), the other should be connected to ground (see also (13, 15) to avoid coupling of noise.

The coupling of the incoming signal is determined by switches (13) and (15) respectively.

(17) OUTPUT connector



BNC connector that provides the processed signal.

(18) FILTER / BYPASS switch



Switch to select whether the unfiltered (BYPASS position) or the filtered (FILTER position) signal is linked to the OUTPUT (17).

(19) GAIN MONITOR



BNC connector monitoring the position of the GAIN switch (+1...+10 V, 1 V / step).

## 4. Literature

Boulton, A. A., Baker, G. B. & Vanderwolf, C. H. (eds.) (1990) *Neurophysiological Techniques, Basic Methods and Concepts*, Humana Press, Clifton, New Jersey.

Kettenmann, H. & Grantyn, R. (eds.) (1992). *Practical Electrophysiological Methods* Wiley-Liss, New York.

Ogden, D. (ed.) (1992) *Microelectrode Techniques - The Plymouth Workshop Handbook*, Second Edition, The Company of Biologists Ltd., Cambridge.

Windhorst, U. & Johansson, H. (eds.) (1999) *Modern Techniques in Neuroscience Research* Springer, Berlin, Heidelberg, New York.

## 5. Technical Data

### INPUT

Input range:	±12 V
Input Impedance:	1 MΩ related to ground (other values possible), input capacitance: 30 pF
AC coupling at input:	corner frequency of 0.1 Hz (if AC /0 /DC switch at BNC connector is switched to AC)

### INPUT PROCESSING

Offset Compensation:	±0.1 V, ±1 V or ±10 V by toggle switch and ten-turn potentiometer (gain=1)
Highpass Filter:	single pole, attenuation: -6 dB/octave, corner frequencies (Hz): DC, 0.1, 0.3, 0.5, 1, 3, 5, 10, 30, 50, 100, 300, 500, 800, 1k, 3k
Lowpass Filter:	8-pole Bessel, attenuation: -48 dB/octave corner frequencies (Hz): 20, 50, 100, 200, 300, 500, 700, 1k, 1.3k, 2k, 3k, 5k, 8k, 10k, 13k, 20k
Notch Filter:	50 Hz (Europe, Asia) or 60 Hz (USA, Canada)
Gain:	rotary switch: 1-2-5-10-20-50-100-200-500-1000
Overload LEDs:	starting to light up at ±10 V

### OUTPUT

Full power bandwidth:	20 kHz
Output impedance:	50 Ω
Output voltage:	max. ±12 V, short-circuit protected
Output current:	max. ±15 mA
Load capacitance:	max. 10 nF
Gain/frequency monitors:	1 V / step
	Gain: +1 V to +10 V
	LP filter: -8 V to +7 V
	HP filter: -8 V to +7 V

### DIMENSIONS

Front panel:	24 HP (121.5 mm) wide x 3U (128.5 mm) high, corresponds to 2 Units
Housing:	7" (175 mm) deep