

OPERATING INSTRUCTIONS AND SYSTEM DESCRIPTION FOR THE

BA-03X

INTRACELLULAR BRIDGE MODE and EXTRACELLULAR AMPLIFIER



VERSION 2.3

npi 2023

npi electronic GmbH, Bauhofring 16, D-71732 Tamm, Germany
Phone +49 (0)7141-9730230; Fax: +49 (0)7141-9730240
support@npielectronic.com; <http://www.npielectronic.com>

Table of Contents

About this Manual	3
1. Safety Regulations	4
2. BA-03X Components	5
3. BA-03X System.....	5
3.1. System Description.....	5
3.2. Description of the Front Panel.....	6
3.3. Description of the Rear Panel.....	16
4. Headstage.....	17
4.1. Headstage Elements.....	17
5. Setting up the BA-03X	18
6. Passive Cell Model	19
6.1. Cell Model Description	19
6.2. Connections and Operation	20
7. Test and Tuning Procedures	22
7.1. Headstage Bias Current Adjustment	22
7.2. Offset Compensation	23
7.3. Capacity Compensation.....	23
7.4. Bridge Balance	25
7.5. Electrode Selection.....	26
7.6. Extracellular Recording, Stimulation and Juxtacellular Filling	26
8. Intracellular Sample Experiments.....	28
8.1. Sample Experiment using a Sharp Electrode	28
8.2. Sample Experiment using a Suction (Patch) Electrode.....	31
8.3. Recordings with the Differential Headstage (optional).....	32
9. Trouble Shooting	34
10. Literature	35
11. Technical Data.....	38
Index.....	40

About this Manual

This manual should help to setup and use the BA-03X system correctly and to perform reliable experiments.

If you are not familiar with the use of instruments for intracellular recording of electrical signals please read the manual completely. The experienced user should read at least chapters, 1, 3, 3.3, 5 and 7.

Important: Please read chapter 1 carefully! It contains general information about the safety regulations and how to handle highly sensitive electronic instruments.

Signs and conventions

In this manual all elements of the front panel are written in capital letters as they appear on the front panel.

System components that are shipped in the standard configuration are marked with 3, optional components with | . In some chapters the user is guided step by step through a certain procedure. These steps are marked with o.

Important information and special precautions are highlighted in gray.

Abbreviations

C_m : cell membrane capacitance

C_{stray} : electrode stray capacitance

GND: ground

I_{max} : maximal current

R_m : cell membrane resistance

R_{EL} : electrode resistance

τ_{Cm} : time constant of the cell membrane

V_{REL} : potential drop at R_{EL}

1. Safety Regulations

VERY IMPORTANT: Instruments and components supplied by npi electronic are NOT intended for clinical use or medical purposes (e.g. for diagnosis or treatment of humans), or for any other life-supporting system. npi electronic disclaims any warranties for such purpose. Equipment supplied by npi electronic must be operated only by selected, trained and adequately instructed personnel. For details please consult the GENERAL TERMS OF DELIVERY AND CONDITIONS OF BUSINESS of npi electronic, D-71732 Tamm, Germany.

- 1) **GENERAL:** This system is designed for use in scientific laboratories and must be operated only by trained staff. General safety regulations for operating electrical devices should be followed.
- 2) **AC MAINS CONNECTION:** While working with npi systems, always adhere to the appropriate safety measures for handling electronic devices. Before using any device please read manuals and instructions carefully.
The device is to be operated only at 115/230 Volt 60/50 Hz AC. Please check for appropriate line voltage before connecting any system to mains.
Always use a three-wire line cord and a mains power-plug with a protection contact connected to ground (protective earth).
Before opening the cabinet, unplug the instrument.
Unplug the instrument when replacing the fuse or changing line voltage. Replace fuse only with an appropriate specified type.
- 3) **STATIC ELECTRICITY:** Electronic equipment is sensitive to static discharges. Some devices such as sensor inputs are equipped with very sensitive FET amplifiers, which can be damaged by electrostatic charge and must therefore be handled with care. Electrostatic discharge can be avoided by touching a grounded metal surface when changing or adjusting sensors. **Always turn power off when adding or removing modules, connecting or disconnecting sensors, headstages or other components from the instrument or 19" cabinet.**
- 4) **TEMPERATURE DRIFT / WARM-UP TIME:** All analog electronic systems are sensitive to temperature changes. Therefore, all electronic instruments containing analog circuits should be used only in a warmed-up condition (i.e. after internal temperature has reached a steady-state value). In most cases a warm-up period of 20-30 minutes is sufficient.
- 5) **HANDLING:** Please protect the device from moisture, heat, radiation and corrosive chemicals.

2. BA-03X Components

The following items are shipped with the BA-03X system:

- 3 BA-03X amplifier
- 3 Headstage
- 3 Ground connector for headstage (2.4 mm)
- 3 Power cord
- 3 User manual

Optional accessories:

- | Sharp electrode holder
- | Suction (patch) electrode holder
- | Electrode holder adapter with BNC connectors

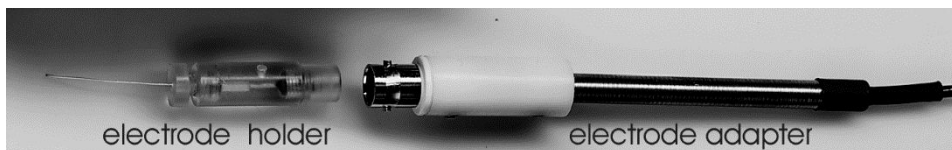

- | Remote switch for penetration unit
- | Active cell model
- | Passive cell model (see Figure 7)
- | Low noise / low bias current headstage with a reduced current range (:10 headstage, i.e. maximal current is 1.2 nA)
- | Headstage with differential input

3. BA-03X System

This manual is related to the standard configuration of the BA-03X system consisting a standard headstage and standard calibrations of bridge balance, electrode resistance display range etc.

Other configurations are available, e.g. if the BA-03X system is used only for whole cell patch clamp recordings with suction electrodes the BA-03X system can be delivered with adapted calibrations and a low noise / low bias current headstage (see **Optional accessories** in chapter 2). For details contact npi.

3.1. System Description

The npi BA-03X recording systems are precise current clamp instruments with a bridge circuit to compensate for the resistance of the recording intracellular electrode. For current injection and potential recording a very high impedance voltage-to-current converter with a special input capacitance compensation circuit is used. The BA-03X is suited for extracellular recording as well because of the built-in potential gain (up to 1000) and potential high and lowpass filters. For methodical reviews see Lalley et al. (1999), Ogden (1994) and Boulton et al. (1990).

The system consists of standard desktop cabinet and a headstage which should be placed close to the recording site. The recording electrode is connected to the headstage via an electrode holder (see also Figure 6). In some setups there is restricted space for placing the headstage

very close to the recording site. In that case the electrode holder can be connected to the headstage via an electrode adapter (see **Optional accessories** in chapter 2).

All electrode connectors use a driven shield approach (for details of this approach see Ogden (1994)) to minimize the effect of the connecting cables. In addition, all headstages are equipped with a ground connector providing system ground. The standard system is equipped with a headstage capable of injecting a maximal current of approximately ± 12 nA (± 120 nA) into a resistance of 100 M Ω (10 M Ω) dependent on the preset current range.

With this headstage the system can be used either with high resistance electrodes for intracellular recordings, or with low resistance suction electrodes for whole cell patch clamp recordings.

The BA-03X is also suitable for extracellular measurements and stimulation with glass or metal electrodes. An extended CURRENT RANGE x10 allows electroporation of single cells for non-invasive, juxtacellular filling of cells with dyes or plasmids as well.

To cover all the needs of electrophysiological research all systems have a large variety of operation- and control elements such as cell penetration mode (BUZZ), ELECTRODE CLEAR facility, ten-turn controls for BRIDGE BALANCE, CAPACITANCE COMPENSATION, OFFSET and HOLDING CURRENT, an automated electrode resistance test, digital displays for potential, current and electrode resistance, a GATE and linear CURRENT STIMULUS INPUT.

3.2. Description of the Front Panel

In the following description of the front panel elements each element has a number that is related to that in Figure 1. The number is followed by the name (in uppercase letters) written on the front panel and the type of the element (in lowercase letters). Then, a short description of the element is given. Some elements are grouped in functional units (e.g. BUZZ unit) and are described as units regardless of the order of numbers.

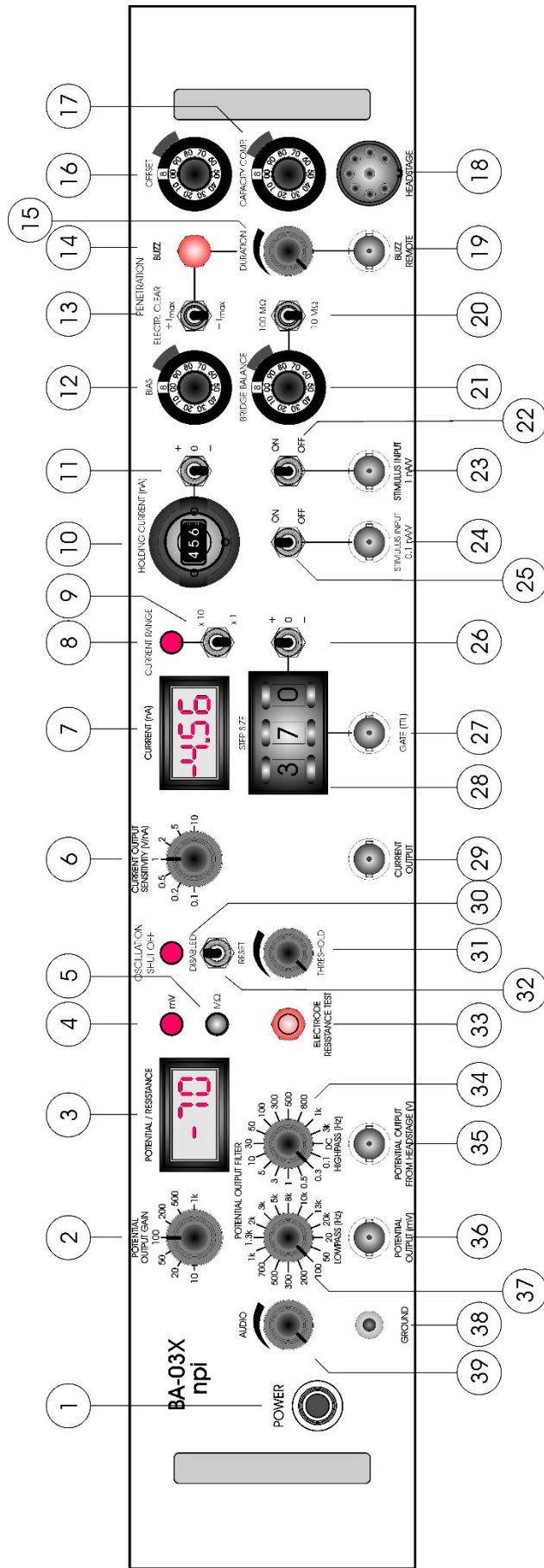

Figure 1: BA-03X front panel view (the numbers are related to those in the text below)

(1) POWER pressure switch

Switch to turn POWER on (switch pushed) or off (switch released).

POTENTIAL OUTPUT unit

The POTENTIAL OUTPUT unit consists of **(2)** POTENTIAL OUTPUT GAIN, **(34)** POTENTIAL OUTPUT FILTER HIGHPASS (Hz), **(35)** POTENTIAL OUTPUT FROM HEADSTAGE (V), **(36)** POTENTIAL OUTPUT (mV) and **(37)** POTENTIAL OUTPUT FILTER LOWPASS (Hz).

(2) POTENTIAL OUTPUT GAIN switch

7-position switch for setting the amplification factor of the recorded potential (x10 to x1k). The amplified voltage signal is available at the POTENTIAL OUTPUT BNC connector **(36)**.

(34) POTENTIAL OUTPUT FILTER HIGHPASS (Hz) switch

16-position switch for setting the corner frequency of the HIGHPASS (1-pole BESSEL) FILTER for the POTENTIAL signal.

(35) POTENTIAL OUTPUT FROM HEADSTAGE (V) connector

BNC connector providing the “raw” potential at the electrode.

(36) POTENTIAL OUTPUT (mV) connector

BNC connector providing the amplified and filtered potential at the electrode.

(37) POTENTIAL OUTPUT FILTER LOWPASS (Hz) switch

16-position switch for setting the corner frequency of the LOWPASS (4-pole BESSEL) FILTER for the POTENTIAL signal.

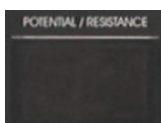
(3) POTENTIAL / RESISTANCE display

LC-Display for the recorded potential in mV (XXXX mV) or the electrode resistance in M Ω (XXXX M Ω , i.e. 100 correspond to 100 M Ω).

(4) mV LED, (5) MΩ LED



LEDs indicating the unit of the reading of the DISPLAY (3).

The resistance is measured accurately regardless of the correct setting of other front panel elements such as OFFSET, BRIDGE BALANCE etc.

Caution: When the ELECTRODE RESISTANCE button is pressed, the BA-03X automatically applies current pulses of ± 1 nA to the electrode. Therefore, it should not be used during recordings from cells since this current may stimulate or damage the cell.

Note: With high resistance electrodes ($R_{EL} > 20$ MΩ) the displayed value is dependent on the accurate setting of the capacity compensation (17).

CURRENT OUTPUT unit

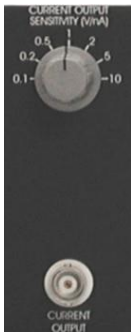

The CURRENT OUTPUT unit consists of (6) CURRENT OUTPUT SENSITIVITY V/nA switch and (29) CURRENT OUTPUT connector.

(6) CURRENT OUTPUT SENSITIVITY V/nA switch

7-position switch for setting the amplification factor of the recorded current (0.1 V/nA to 10 V/nA).

(29) CURRENT OUTPUT connector

BNC connector monitoring the stimulating current passed through the electrode (sensitivity set by switch (6))

Note: The maximum voltage an this connector is ± 12 V. This has to be considered if large currents are applied.

(7) CURRENT (nA) display



LC display showing the stimulating current passed through the electrode.

CURRENT RANGE unit



The CURRENT OUTPUT unit consists of **(8)** CURRENT RANGE LED and **(9)** CURRENT RANGE switch

(8) CURRENT RANGE LED

The CURRENT RANGE LED indicates the setting x10 (± 120 nA) of switch **(9)** (LED: ON).

(9) CURRENT RANGE switch

Switch for setting the CURRENT RANGE of the amplifier: **x1**: max. ± 12 nA into 1 G Ω , **x10**: max. ± 120 nA into 100 M Ω

HOLDING CURRENT unit



The HOLDING CURRENT unit consists of **(10)** HOLDING CURRENT (nA) potentiometer and **(11)** + / 0 / - switch (holding current switch).

(10) HOLDING CURRENT (nA) potentiometer

With this control a constant current (holding current) can be generated (ten turn potentiometer, clockwise), calibrated in nA ($I_{\max} = 10$ nA or 100 nA, dependent on setting of CURRENT RANGE switch **#9**). The polarity of the holding current is set by toggle switch **(11)**.

(11) + / 0 / - switch (holding current switch)

Switch to disable holding current generation or to set the polarity of the holding current (+: current positive, 0: holding current disabled, -: current negative).

(12) BIAS (bias current) potentiometer



10 turn potentiometer for setting the output current of the headstage (headstage BIAS current) to zero (ten-turn potentiometer, symmetrical, i.e. 0 pA = 5 on the dial), range: ± 150 pA (current range: **x1** and **x10**), (see chapter 7.1).

PENETRATION unit



The PENETRATION unit consists of (13) ELECTR. CLEAR switch, (14) BUZZ push button, (15) DURATION potentiometer and (19) BUZZ REMOTE connector.

(13) ELECTR. CLEAR switch

The ELECTR. CLEAR switch is used to activate the ELECTRODE CLEAR circuit that can be used to clean the tip of the electrode by passing large amounts of positive or negative current. The circuit is operated by pushing this switch to $+I_{\max}$ (maximum positive current) or $-I_{\max}$ (maximum negative current). The maximum current is dependent on the setting of the current range, see also (9).

(14) BUZZ push button

Push button for activating the BUZZ or ELECTR. CLEAR circuit (duration set by (15)). To facilitate the penetration of the cell membrane the BUZZ circuit is provided which is based on oscillations caused by overcompensating the capacity compensation system. The overcompensation of capacity compensation yields to very powerful high-frequency oscillations (see Figure 2).

(15) DURATION potentiometer

Control to set the duration of the BUZZ (potentiometer, clockwise, range: ~ 1 ms to ~ 100 ms). The duration is dependent on the setting of CAPACITY COMP (17). It is effective in REMOTE control and when pushing the BUZZ button (14).

(19) BUZZ REMOTE connector

BNC connector to attach a remote switch to the PENETRATION unit.

potential (mV)

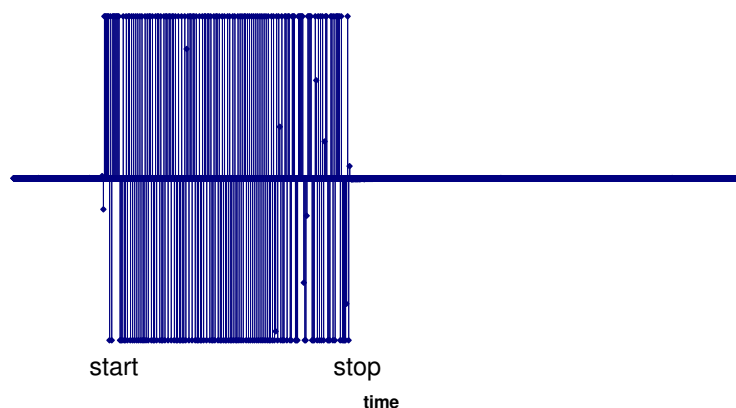

Figure 2: buzz function of the BA-03X

(16) OFFSET potentiometer



Control to compensate for the electrode OFFSET (ten-turn potentiometer, symmetrical, i.e. 0 mV = 5 on the dial), range: ± 200 mV (see chapter 7.2).

(17) CAPACITY COMP. potentiometer

Control for the compensation of the input capacitance (ten turn potentiometer, clockwise, range: 0-30 pF, see chapter 7.3).

Caution: This circuit is based on a positive feedback circuit. Overcompensation leads to oscillations which may damage the cell.

Important: The capacity compensation for the electrode does NOT work if the oscillation shut-off circuit is activated. This may lead to an incorrect reading of the electrode resistance (see also 33) especially when electrodes with high resistances are used.

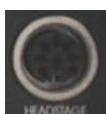
(18) HEADSTAGE connector

The HEADSTAGE is connected via a flexible cable and a 8-pole connector to the mainframe (see also chapter 3.3).

Caution: Please always adhere to the appropriate safety regulations (see chapter 1). Please turn power off when connecting or disconnecting the headstage from the HEADSTAGE connector!

BRIDGE BALANCE unit

The BRIDGE BALANCE unit consists of **(20)** 100 M Ω / 10 M Ω RANGE switch and **(21)** BRIDGE BALANCE potentiometer.

(20) 100 M Ω / 10 M Ω RANGE switch

Switch to set the RANGE of the BRIDGE BALANCE potentiometer (100 M Ω position: RANGE 0 M Ω to 1000 M Ω , 10 M Ω position: RANGE 0 M Ω to 100 M Ω)

(21) BRIDGE BALANCE(M Ω) potentiometer

If current is passed through the recording electrode the potential deflection caused at the electrode resistance is compensated with this control (ten turn potentiometer, clockwise, calibrated in M Ω , RANGE: set by switch **(20)**, see also chapter 7.4).

CURRENT INPUT unit

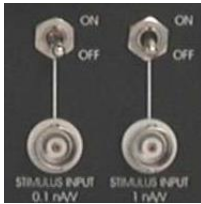

The CURRENT INPUT unit consists of (22) (25) ON / OFF switches, (23) STIMULUS INPUT 1 nA/V connector and (24) STIMULUS INPUT 0.1 nA/V connector.

(22) ON / OFF switch

Switch to enable (ON) or disable (OFF) STIMULUS INPUT via 1 nA/V connector.

To avoid interferences always switch to OFF position if the INPUT is not used.

(23) STIMULUS INPUT 1 nA/V connector

Analog input BNC connector for applying signals from an external stimulus source. The voltage signal that is connected here is transformed to a proportional current at the electrode with a sensitivity of 1 nA/V, i.e. an input voltage of 5 V is transformed to an output current of 5 nA (if switch (9) is set to x1). The signal form remains unchanged. Two examples are given in Figure 3. The amplitude of the output current signal (CURRENT STIMULUS) is determined by the amplitude of the input voltage signal.

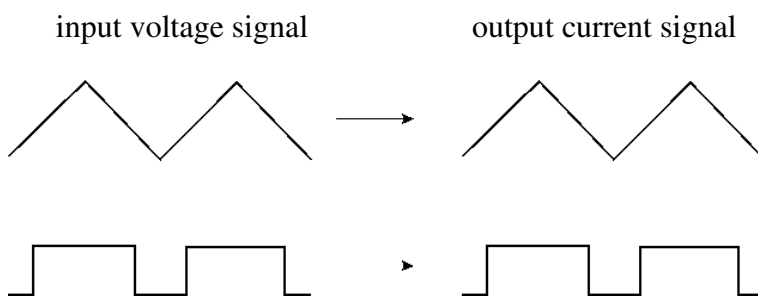

Figure 3: input-output relation using STIMULUS INPUT

(24) STIMULUS INPUT 0.1 nA/V connector

Analog input BNC connector for applying signals from an external stimulus source. The voltage signal that is connected here is transformed to a proportional current at the electrode with a sensitivity of 0.1 nA/V, i.e. an input voltage of 5 V is transformed to an output current of 0.5 nA (if switch (9) is set to x1). The signal form remains unchanged (see also 23 and Figure 3).

Very Important: If switch (9) is set to x10, all current input signals are multiplied by the factor of 10, i.e. STIMULUS INPUT 1 nA/V is then 10 nA/V and 0.1 nA/V is 1 nA/V, respectively!!

Important: The current injected through the electrode is always the sum of the input signals at STIMULUS INPUT (23 or 24), the holding current set by HOLDING CURRENT (10) and switch (11), and the gated stimulus set by STEP SIZE (28) and switch (26).

(25) ON / OFF switch

Switch to enable (ON) or disable (OFF) STIMULUS INPUT via 0.1 nA/V connector.

Hint: To avoid interferences always switch to OFF position if the INPUT is not used.

gated stimulus unit



The gated stimulus unit consists of **(26)** + / 0 / - switch (STEP SIZE switch), **(27)** GATE (TTL) connector and **(28)** STEP SIZE digital potentiometer.

(26) + / 0 / - switch (STEP SIZE switch)

+ / 0 / - toggle switch to disable the gated stimulus set by STEP SIZE **(28)** and gated by GATE (TTL) **(27)**, or to select the polarity of the gated stimulus (+: gated stimulus positive, 0: gated stimulus disabled, -: gated stimulus negative).

(27) GATE (TTL) connector

With this input a current step (gated stimulus) can be generated set by the digital potentiometer STEP SIZE **(28)** and the polarity switch **(26)**. This current step is gated by a positive TTL pulse (3-5 V) applied to the BNC connector. Two examples are given in Figure 4. The duration of the current step is set by the duration of the gating signal. The amplitude of the current step is set by STEP SIZE **(28)**.

(28) STEP SIZE digital potentiometer

Control to set the amplitude of the gated stimulus (digital potentiometer

X.XX nA, range: ± 9.99 nA, resolution 10 pA (if switch **(9)** is set to x1)

or

XX.X nA, range: ± 99.9 nA, resolution 100 pA (if switch **(9)** is set to x10)

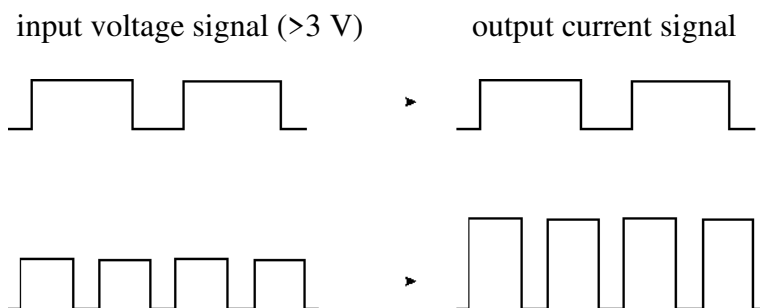

Figure 4: input-output relation using gated stimuli

OSCILLATION SHUT-OFF unit



The OSCILLATION SHUT-OFF unit consists of **(30)** OSCILLATION SHUT-OFF LED, **(31)** THRESHOLD potentiometer and **(32)** DISABLED/RESET switch.

(30) OSCILLATION SHUT-OFF LED

Indicates whether the OSCILLATION SHUT-OFF circuit is active (LED: red) or not (LED: green).

(31) THRESHOLD potentiometer

Control to set the activation THRESHOLD of the OSCILLATION SHUT-OFF circuit (potentiometer, linear clockwise, range: 0-1200 mV).

(32) DISABLED/RESET switch

Switch to DISABLE the OSCILLATION SHUT-OFF unit or RESET the circuit. RESET is done if one wants to reset the circuit after previous activation. After resetting the OSCILLATION SHUT-OFF unit is active again.

Note: If the OSCILLATION SHUT-OFF unit is active, the output of the amplifier to the headstage is disabled. Potential measurement works.

Important: The capacity compensation for the electrode does NOT work if the oscillation shut-off circuit is activated. This may lead to an incorrect reading of the electrode resistance (see also **33**) especially when electrodes with high resistances are used.

(33) ELECTRODE RESISTANCE TEST push button



Push button to start the measurement of the electrode resistance. When this button is pressed the DISPLAY **(3)** shows the electrode resistance in $M\Omega$ (see also **(3)**).

Important: The reading of the electrode resistance is correct only if the electrode capacitance is accurately compensated. Therefore, it might be incorrect if the oscillation shut-off circuit is activated.

(38) GROUND connector



Banana jack that is linked to the internal system ground which has no connection to the 19" cabinet and the mains ground to avoid ground loops.

(39) AUDIO monitor potentiometer



Potentiometer for setting the volume of the internal speaker. The AUDIO function of the BA-03X converts the potential output into a tone with a frequency equivalent to the amplitude of the potential.

Note: Very small signals of only one or a few mV are probably not well monitored by the AUDIO monitor, especially in extracellular recordings. This function is intended to monitor

acoustically the transition of extracellular to intracellular when penetrating a cell which is accompanied by a large voltage drop of several tens of mV.

3.3. Description of the Rear Panel

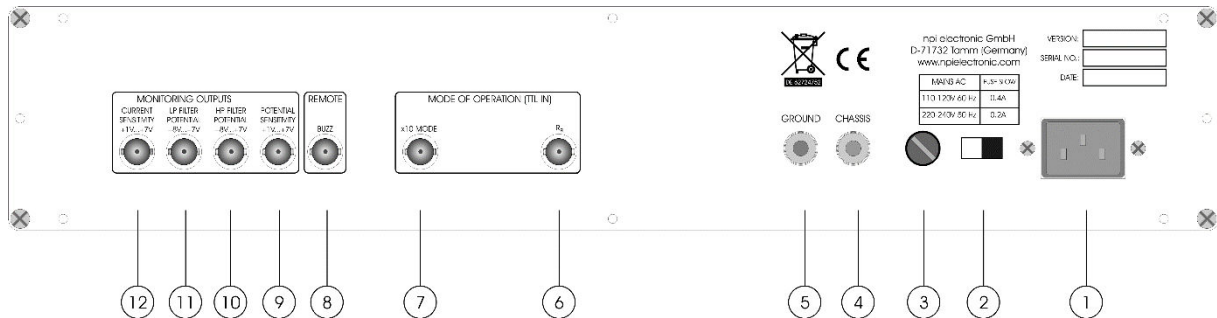

Figure 5: BA-03X rear panel view (the numbers are related to those in the text below)

(1) Mains connector

Plug for connecting the BA-03X to mains.

Caution: Always switch to the appropriate voltage before connecting the BA-03X to power.

(2) Voltage SELECTOR

Switch for selecting the mains voltage (110 V-120 V / 220 V-240 V).

Caution: Always switch to the appropriate voltage before connecting the BA-03X to power.

(3) FUSE holder

Holder for the line fuse. For changing the fuse rotate the holder counter clockwise using a screw driver. The appropriate fuse type is listed above the holder.

(4) CHASSIS

This connector is linked to mains ground (green / yellow wire, protective earth).

(5) GROUND

This connector is linked to the internal system ground which has no connection to the 19" cabinet (CHASSIS) and the mains ground to avoid ground loops.

MODES of OPERATION connectors

(6) R_{EL} connector

BNC connector for connecting a TTL signal that activates the electrode resistance test. TTL HI = R_{EL} on, TTL LOW = R_{EL} off.

(7) x10 MODE connector

BNC connector for connecting a TTL signal that activates the x10 current mode (see also #9, Figure 1). TTL HI = x10 current mode, TTL LOW = x1 current mode.

REMOTE connector

(8) BUZZ connector

BNC connector for connecting a TTL signal that activates the BUZZ function (see also #14, Figure 1). TTL HI = BUZZ on, TTL LOW = BUZZ off.

MONITOR OUTPUT connectors

(9) POTENTIAL SENSITIVITY connector

BNC connector providing a voltage monitoring the position of the POTENTIAL OUTPUT GAIN switch (+1 V to +7 V, 1V/STEP).

(10) HP FILTER POTENTIAL connector

BNC connector providing a voltage monitoring the position of the POTENTIAL HIGHPASS FILTER switch (-8 V to +7 V, 1V/STEP).

(11) LP FILTER POTENTIAL connector

BNC connector providing a voltage monitoring the position of the POTENTIAL LOWPASS FILTER switch (-8 V to +7 V, 1V/STEP).

(12) CURRENT SENSITIVITY connector

BNC connector providing a voltage monitoring the position of the CURRENT OUTPUT SENSITIVITY switch (+1 V to +7 V, 1V/STEP).

4. Headstage

The BA-03X comes with the standard headstage (range: ± 12 nA, voltage range x1 or ± 120 nA, voltage range x10) for connecting glass electrodes with high resistances or suction electrodes for whole cell patch clamp recordings with lower resistances via an electrode holder (see Figure 6).

A low noise / low bias current headstage (range: ± 1.2 nA, voltage range x1 or ± 12 nA, voltage range x10, see also **Optional accessories** in chapter 2) for very small currents is also available. For details contact npi.



Figure 6: electrode holder (optional) and headstage of the BA-03X

4.1. Headstage Elements

- 1 BNC connector for the optional electrode holder
- 2 REF: connector for the reference electrode (differential headstage only)
- 3 GND: Ground connector
- 4 headstage cable/holding bar

The electrode filled with electrolyte is inserted into an electrode holder (optional, see Figure 6) that fits into the BNC connector of the headstage or into an electrode holder adapter (optional, see also **Optional accessories** in chapter 2). The electrical connection between the electrolyte and the headstage is established using a carefully chlorinated silver wire. Chlorinating of the silver wire is very important since contact of silver to the electrolyte leads to electrochemical potentials causing varying offset potentials at the electrode, deterioration of the voltage measurement etc. (for details see Kettenmann and Grantyn (1992)). For optimal chlorinating of silver wires an automated chlorinating apparatus (ACI-01) is available (please contact npi for details).

Ground provides system ground and is linked to the bath via an agar-bridge or a Ag-AgCl pellet. The headstage is attached to the amplifier with the headstage cable (see #4, Figure 6) and a 8-pole connector. The headstage is mounted to a holding bar that fits to most micromanipulators or optionally to a mounting plate or a dovetail adapter.

Note: The shield of the BNC connector is linked to the driven shield output and must not be connected to ground.

Caution: Please always adhere to the appropriate safety precautions (see chapter 1). Please turn power off when connecting or disconnecting the headstage from the HEADSTAGE connector!

5. Setting up the BA-03X

The following steps should help you set up the BA-03X correctly. Always adhere to the appropriate safety measures (see chapter 1).

After unpacking, the BA-03X is attached to the setup by assembling the electrical connections. It is assumed that a cell model will be attached. The connection of the Ag-AgCl pellet or the agar-bridge for grounding the bath is described in chapter 8.

⌘ Electrical connections

- o Turn POWER off.
- o Plug the power cord of the instrument into a grounded outlet.
- o Connect the headstage to the HEADSTAGE connector (#18, Figure 1) at the BA-03X.
- o Connect a cell model (see chapter 6). Connect a digital/analog timing unit or a stimulation device to STIMULUS INPUT or to GATE (TTL) if you intend to use the gated stimulus unit.
- o Connect a store oscilloscope or a data acquisition system to the POTENTIAL OUTPUT and to the CURRENT OUTPUT triggered from the stimulation device. Set the desired gain at the POTENTIAL OUTPUT GAIN switch (#2, Figure 1) and the CURRENT OUTPUT SENSITIVITY switch (#6, Figure 1).

Before using the BA-03X always make the basic settings to avoid oscillations.

⌘ Basic settings

- o Turn all controls to low values (less than 1) and the OFFSET in the range of 5 (zero position, see chapter 3.2).
- o Set the CURRENT RANGE switch (#9, Figure 1) to x1.

- o Turn POWER switch on.

Now the BA-03X is ready for an initial check with the cell model.

6. Passive Cell Model

The BA-03X can be ordered with a passive cell model as an optional accessory. An active cell model is also available on request (for ref. see Draguhn et al. (1997)).

The passive cell model is designed for use with single electrode amplifiers (BA series, ELC series) to check the function of the instrument in the following circumstances:

1. just after unpacking to see whether the instrument has been damaged during transport or
2. to train personnel using the instrument or
3. in case of trouble (see also chapter 9) to check which part of the setup does not work correctly, e.g. to find out whether the amplifier or headstage is damaged, or something is wrong with the electrodes or holders etc.

The passive cell model consists only of passive elements, i.e. resistors that simulate the resistance of the cell membrane and the electrodes, and capacitances that simulate the capacitance of the cell membrane. A switch allows simulation of two different cell types: a cell with 50 M Ω and 22 pF (CELL 1, represents an astrocyte like cell) or a “small” cell with 200 M Ω membrane resistance and 100 pF membrane capacitance (CELL 2, represents an neuron like cell), or. Electrode immersed into the bath or SEAL formation can be mimicked as well. The headstage of the amplifier can be connected to one of two different types of electrodes (see below).

6.1. Cell Model Description

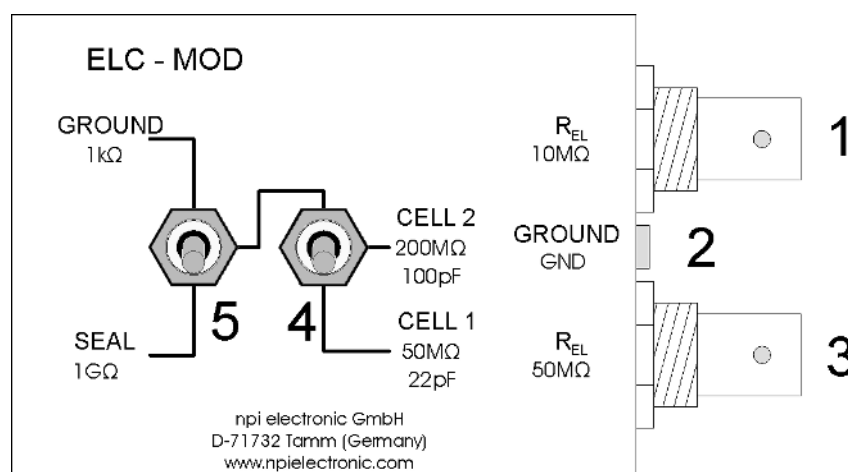

Figure 7: passive cell model

- 1, 3:** connectors for the headstage, **1:** electrode resistance: $50\text{ M}\Omega$, **3:** electrode resistance: $10\text{ M}\Omega$
- 2:** GND ground connector, to be connected to GND jack of the headstage
- 4:** CELL: switch for cell membrane representing a membrane of either $50\text{ M}\Omega$ and 22 pF (CELL 1) or $200\text{ M}\Omega$ and 100 pF (CELL 2).
- 5:** In GROUND (upper) position the electrodes are connected to ground via a $1\text{ k}\Omega$ resistor. In SEAL (lower) position are connected to a $1\text{ G}\Omega$ resistor simulating the formation of a GIGASEAL with a patch electrode.

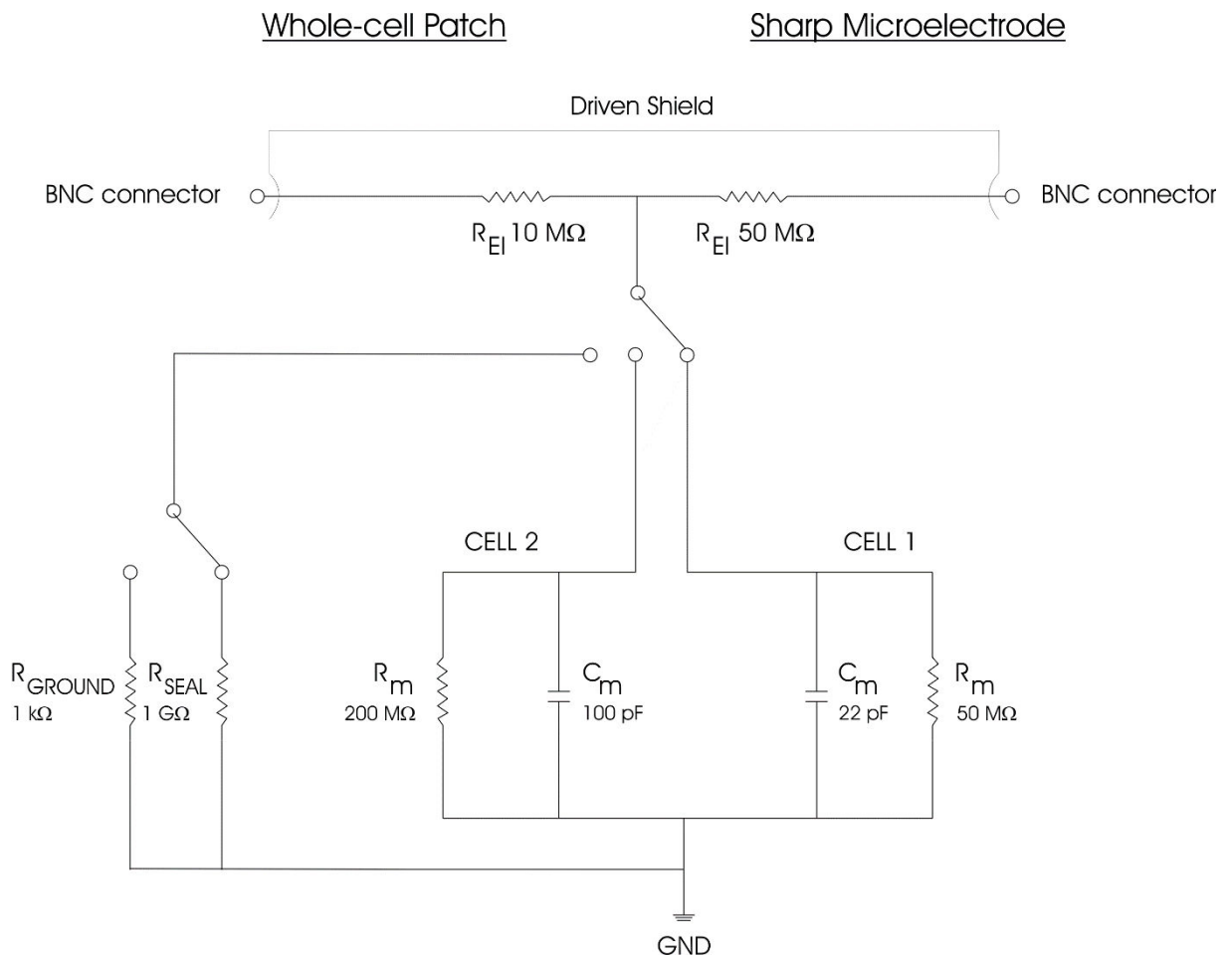

Figure 8: Schematic diagram of the passive cell model

6.2. Connections and Operation

It is assumed that all connections are built as described in chapter 5.

Checking the configuration

- o Turn POWER switch of the amplifier off.
- a) For simulation of an experiment using a suction electrode

- o Connect the BNC jack labeled $10\text{M}\Omega$ of the cell model to the BNC connector P_{EL} of the headstage.
- b) For simulation of an experiment using a sharp electrode
 - o Connect the BNC jack labeled $50\text{M}\Omega$ of the cell model to the BNC connector P_{EL} at the headstage. For headstages with SMB connector use the supplied SMB to BNC adapter.

For a) and b)

- o Connect GND of the cell model to GND of the headstage.

Important: When using the **differential headstage (optional)** the **REF connector** must not be left open. It must be connected to ground.

Simulation of electrode in the bath

- o Set switch #4, Figure 7 to the upper position.
- o Set switch #5, Figure 7 to GROUND position. The $1\text{ k}\Omega$ resistor simulates the resistance of the bath solution. This can be used to train cancellation of offsets, using the bridge balance and using the capacity compensation.

Simulation of SEAL formation

- o Set switch #4, Figure 7 to the upper position.
- o Set switch #5, Figure 7 to SEAL position. The $1\text{ G}\Omega$ resistor simulates the SEAL resistance when forming a GIGASEAL in patch clamp experiments.

Simulation of intracellular recording

Intracellular recordings can be mimicked with one of two cells with different properties. Use the $50\text{ M}\Omega$ electrode connector (#1, Figure 7) for an experiment with sharp electrodes or the $10\text{ M}\Omega$ electrode connector (#3, Figure 7) for simulating an experiment with patch electrodes.

- o Switch the CELL membrane switch (see #4, Figure 7) to the desired position (CELL 1 or CELL 2).
- o Turn all controls at the amplifier to low values (less than 1) and the OFFSET in the range of 5 (zero position) and the OSCILLATION SHUTOFF in the DISABLED position.
- o Turn POWER switch of the amplifier on.

Now you can adjust the amplifier (see below) and apply test pulses to the cell model. The lower position of the CELL membrane switch (CELL 1) simulates a cell with a resistance of $50\text{ M}\Omega$ and a capacitance of 22 pF . In the middle position (CELL 2) a cell membrane with $200\text{ M}\Omega$ and 100 pF is simulated.

7. Test and Tuning Procedures

Important: The BA-03X should be used only in warmed-up condition, i.e. 30 minutes after turning power on.

The following test and tuning procedures are necessary for optimal recordings. It is recommended first to connect a cell model to the amplifier in order to perform some basic adjustments and to get familiar with these procedures. It is assumed that all connections are built as described in chapter 5.

Important: Except for *Headstage Bias Current adjustment* (see 7.1) all adjustments described below should be carried out every time before starting an experiment or after changing the electrode.

7.1. Headstage Bias Current Adjustment

Caution: It is very important that this tuning procedure is performed **ONLY** after a warm-up period of at least 30 minutes, since the bias current changes significantly during warm up!

The BA-03X system is equipped with a voltage-to-current converter with a very high output impedance which is connected to the recording electrode. The zero current of this unit is tuned with the BIAS current control (#12, Figure 1, chapter 3.2).

The tuning procedure must be performed regularly (about once a month) since the bias current changes over time. If very small currents are used (in the 10 pA range) the procedure must be repeated in shorter intervals.

The tuning procedure is performed using high-value resistors and/or a cell model. It cannot be performed with an electrode, since there are always unknown potentials involved (tip potential, junction potentials, etc.).

- o Disconnected **all** input signals (except the headstage). Put the holding current switch to position 0 (+ / 0 / - switch, #11, Figure 1).
- o Connect the MICROELECTRODE connector of the headstage to ground. If parasitic oscillations occur use a 10 k Ω resistor for grounding.

Note: This cannot be done with the cell model. Please use a wire to connect the input of the BNC connector on the headstage to GND of the headstage. Do not use the shield of the BNC connector since it is connected to driven shield.

- o Tune the OFFSET to zero using the OFFSET control (#16, Figure 1, see also chapter 7.2).
- o After tuning the OFFSET connect the cell model via the 50 M Ω connector (sharp electrode). If you do not use a cell model remove the wire and attach a resistor with a value of about 5 to 10 M Ω across the same connection.
- o The value displayed at the DISPLAY (#3, Figure 1) is related to the BIAS current of the headstage according to Ohm's Law. Cancel this voltage by tuning the headstage BIAS current potentiometer (#12, Figure 1).
- o *Accuracy:* Now both displays (potential / current) the should read 000. Due to the limited resolution of the display, unbalanced offsets and thermal drifts an offset of ± 001 to ± 002 can occur on the display. This small deviation can be trimmed internally, but this procedure is necessary only if very small currents in the pA range must be applied exactly.

7.2. Offset Compensation

If an electrode is immersed into the bath solution an offset voltage will appear, even if no current is passed. This offset potential is the sum of various effects at the tip of the electrode filled with electrolyte (“tip potential”, junction potential etc.). This offset voltage must be compensated, i.e. set to zero carefully with the OFFSET control (#16, Figure 1) before recording from a cell. When adjusting the OFFSET make sure that no current flows through the electrode. Thus, it is recommended to disconnect CURRENT INPUT and to disable GATE (TTL) STEP SIZE and the HOLDING CURRENT unit (see chapter 3.2).

If a cell model is connected the OFFSET control should read a value around 5, otherwise it is likely that the headstage or the amplifier is damaged.

7.3. Capacity Compensation

High resistances of electrodes and stray capacitances (C_{stray}) form a low-pass filter that deteriorates the shape of recorded intracellular signals (see also Figure 11). The frequency response of the amplifier is improved considerably by using the capacitance compensation function. This function is based on positive feedback (“negative capacitance”) circuit. The tuning of the capacitance compensation control is performed using pulses applied to the CURRENT INPUT or pulses provided by the electrode resistance test circuit.

With the cell model connected or the electrode in the bath the CAPACITY COMP. control is turned clockwise until there is no capacitance artifact on the POTENTIAL OUTPUT (see Figure 9).

- o Make the basic settings at the amplifier (see chapter 5).
- o Connect a cell model or immerse the electrode into the bath as deep as necessary during the experiment.
- o Tune the OFFSET to zero (see chapter 7.2)
- o Press the ELECTRODE RESISTANCE button (#33, Figure 1) or apply rectangular pulses to the CURRENT STIMULUS INPUT and watch the POTENTIAL OUTPUT.
- o Compensate the input capacitance as shown in Figure 9 using the CAPACITY COMP. potentiometer (#17, Figure 1).

Figure 9 illustrates the capacitance compensation procedure using a 100 M Ω resistor that represents the electrode. The pulses were generated using the automated electrode resistance test circuit of the BA-03X. The upper diagram shows an undercompensated capacitance. In the diagram in the middle the capacitance is slightly overcompensated and in the lower diagram it is well compensated.

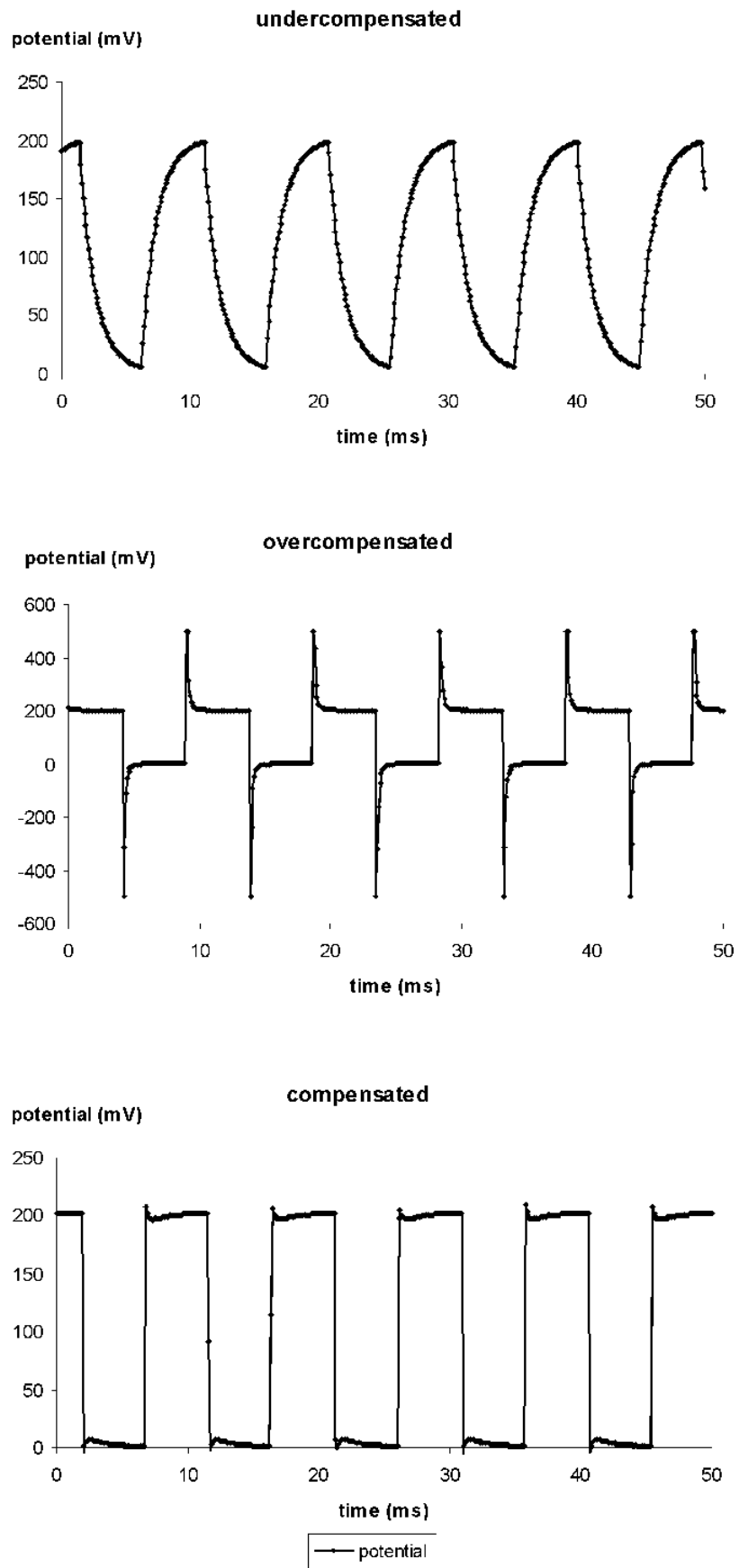

Figure 9: Tuning of the capacitance compensation using a 100 MΩ resistor

7.4. Bridge Balance

If current is passed through an electrode the occurring voltage deflection (potential drop at R_{EL}) affects the recording of membrane potential. Therefore this deflection must be compensated carefully by means of the BRIDGE BALANCE control. This control is calibrated in $M\Omega$ and has two ranges selected by a RANGE switch (#20, Figure 1).

With the cell model connected or the electrode in the bath the BRIDGE BALANCE control is turned on clockwise until there is no artifact on the POTENTIAL OUTPUT (see Figure 10).

- o Make the basic settings at the amplifier (see chapter 5).
- o Connect a cell model or immerse the electrode into the bath as deep as necessary during the experiment.
- o Tune the OFFSET to zero (see chapter 7.2) and compensate the input capacitance (see chapter 7.3). This is very important since a badly compensated input capacitance prevents setting the BRIDGE BALANCE to correct values.
- o Determine the electrode resistance using the ELECTRODE RESISTANCE switch and set the BRIDGE BALANCE RANGE switch (#20, Figure 1) accordingly.
- o Apply current pulses to the electrode either using an external stimulator (via the CURRENT INPUT connector (#23, #24, Figure 1) or by using the gated stimulus unit.
- o Watch the POTENTIAL OUTPUT at the oscilloscope and adjust the BRIDGE BALANCE as shown in Figure 10 using the BRIDGE BALANCE potentiometer (#21, Figure 1). After adjustment you should see a straight voltage trace without artifacts caused by the potential drop at R_{EL} .

Figure 10 illustrates the BRIDGE BALANCE procedure using a $100 M\Omega$ resistor that represents the electrode. The current stimuli were generated using the gated stimulus unit gated by two TTL pulses. The amplitude was set to $0.5 nA$. In the upper diagram the bridge is slightly undercompensated and in the diagram in the middle it is slightly overcompensated. The lower diagram shows a well balanced bridge (compensated).

Important: BRIDGE BALANCE and CAPACITY COMP. must be tuned several times during an experiment since most parameters change during a recording session. Figure 13 shows artifacts caused by uncompensated stray capacitance and bridge during recording from a cell. It also shows how to cancel these artifacts by tuning with CAPACITY COMP. and BRIDGE BALANCE.

OFFSET deviations can be detected by comparing the readout on the potential display before and after an experiment (with the electrode in the tissue or bath, but not in a cell).

7.5. Electrode Selection

Electrodes must be tested before use. This is done by applying positive and negative current pulses and by compensating with the BRIDGE BALANCE control. Electrodes which show significant changes in resistance (rectification) cannot be used for intracellular recordings. By increasing the current amplitude the capability of the electrode to carry current can be estimated. The test current must cover the full range of currents used in the experiment. Sometimes the performance of electrodes can be improved by breaking the tip or by using the BUZZ or ELECTRODE CLEAR facilities of the amplifier.

7.6. Extracellular Recording, Stimulation and Juxtacellular Filling

The BA-03X can also be used for extracellular recordings with glass or metal electrodes. Recording with extracellular metal electrodes is simple. The electrode is advanced into the region where the recordings will be made using a micromanipulator and the signals are filtered and amplified (see chapter 5 in Lalley et al., 1999 for details) as required.

The recorded signal is amplified with the factor set by switch #2, Figure 1 and filtered using the LOWPASS filter and/or HIGHPASS filter (#34, Figure 1).

Since the BA-03X is capable of current injection, the amplifier can be used for extracellular stimulation or electroporation as well. Normally, a current of few nA are used for extracellular stimulation. Electroporation can be done using the extracellular stimulation procedure, but usually the applied current is much higher and the stimulus duration is shorter. Therefore, most electroporation experiments are done in CURRENT RANGE x10 mode (#9, Figure 1). This enables the BA-03X to perform juxtacellular filling of individual cells with dyes or nucleic acids.

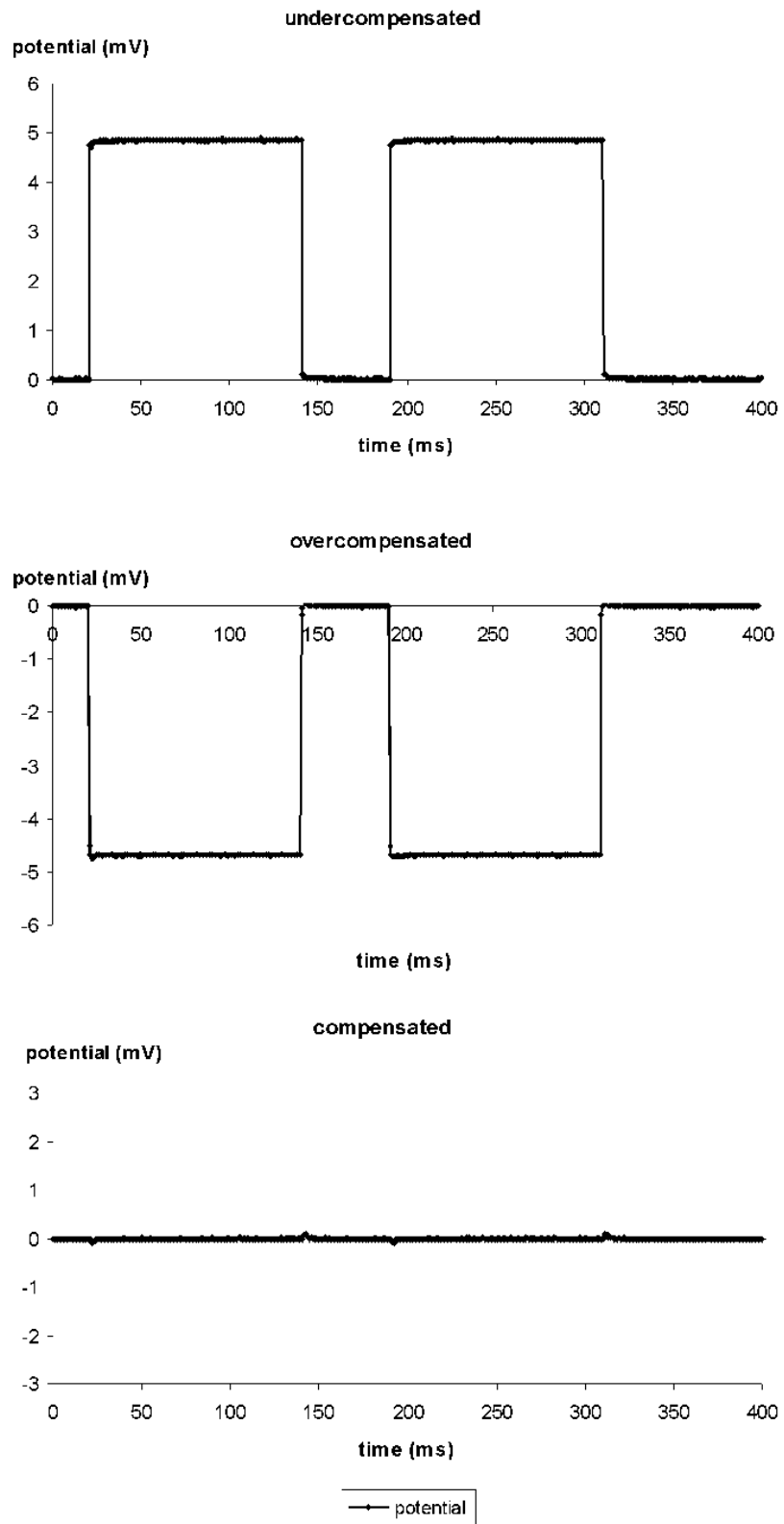

Figure 10: Tuning of the BRIDGE BALANCE using 100 MΩ resistor

8. Intracellular Sample Experiments

In the following the basics of a simple intracellular experiment are described either using a sharp or a suction electrode.

It is assumed that all connections are built as described in chapter 5. Before starting remove the cell model.

8.1. Sample Experiment using a Sharp Electrode

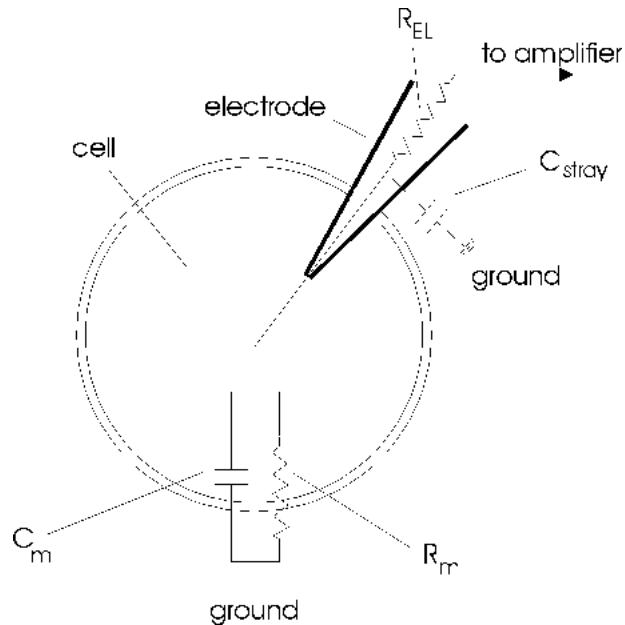

Figure 11: Model circuit for intracellular recording using a sharp electrode
 C_m : membrane capacitance, C_{stray} : electrode stray capacitance, R_{EL} : electrode resistance, R_m : membrane resistance

- o Connect the electrode cable / holder to the BNC connector and the Ag-AgCl pellet or the agar-bridge for grounding the bath with GND at the headstage.
- o Make the basic settings (see chapter 5).

Again: It is of major importance that the BA-03X systems are used only in warmed-up condition, i.e. 20 to 30 minutes after turning power on.

- o Adjust BIAS CURRENT to zero if necessary (see chapter 7.1)
- o Reconnect the STIMULUS INPUT and/or the GATE (TTL) STEP SIZE and put an electrode into the electrode holder.
- o Immerse the electrode into the bath (not in a cell) as deep as necessary during the experiment. Test the capability of the electrode to carry current (see chapter 7.4), compensate the potential offset (see chapter 7.2), measure the electrode resistance (see #33, chapter 3.2) and compensate the input capacitance (see chapter 7.3 and Figure 9).
- o Enable the OSCILLATION SHUT-OFF unit (#32, Figure 1) and set the THRESHOLD (#31, Figure 1) in a way that the OSCILLATION SHUT-OFF unit activates if the system

begins to oscillate. Test this by overcompensating the electrode capacitance in several positions of the THRESHOLD potentiometer.

- o Now the system is preadjusted for measurements. Find a cell!
- o Approach the desired cell. There are several indications that the electrode is very close to the cell membrane:
 - the electrode resistance increases (the bridge balance appears undercompensated)
 - extracellular action potentials (APs) are recorded
 - the acoustic monitor signal changes
- o Set the BUZZ DURATION potentiometer to one fourth and apply a BUZZ to the electrode.
- o If you are lucky the tip of the electrode is now inside the cell.
- o If necessary readjust the BRIDGE BALANCE as shown in Figure 12.
- o You read the membrane potential and can apply current pulses to the cell. After penetration the voltage responses of the cell to the test pulses should reflect the cell membrane resistance and time constant.
- o Start the experiment.

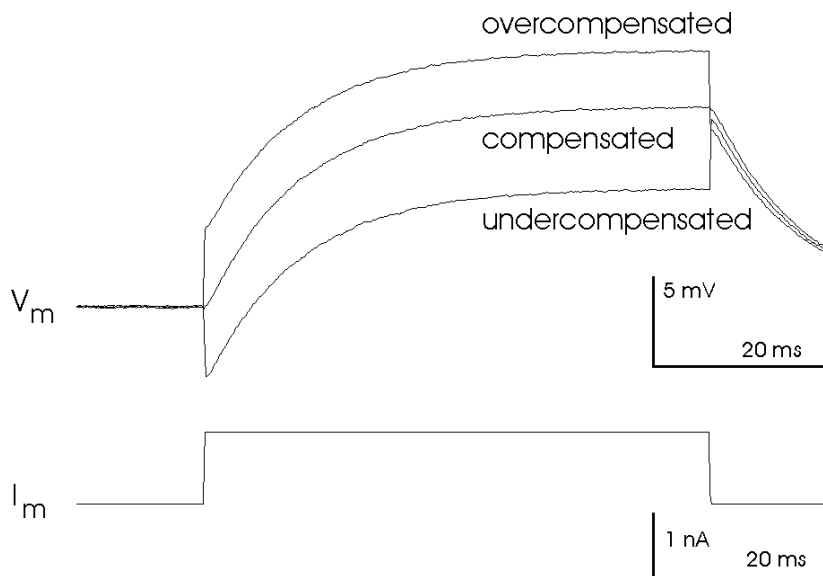

Figure 12: Adjustment of the bridge balance after penetrating a cell

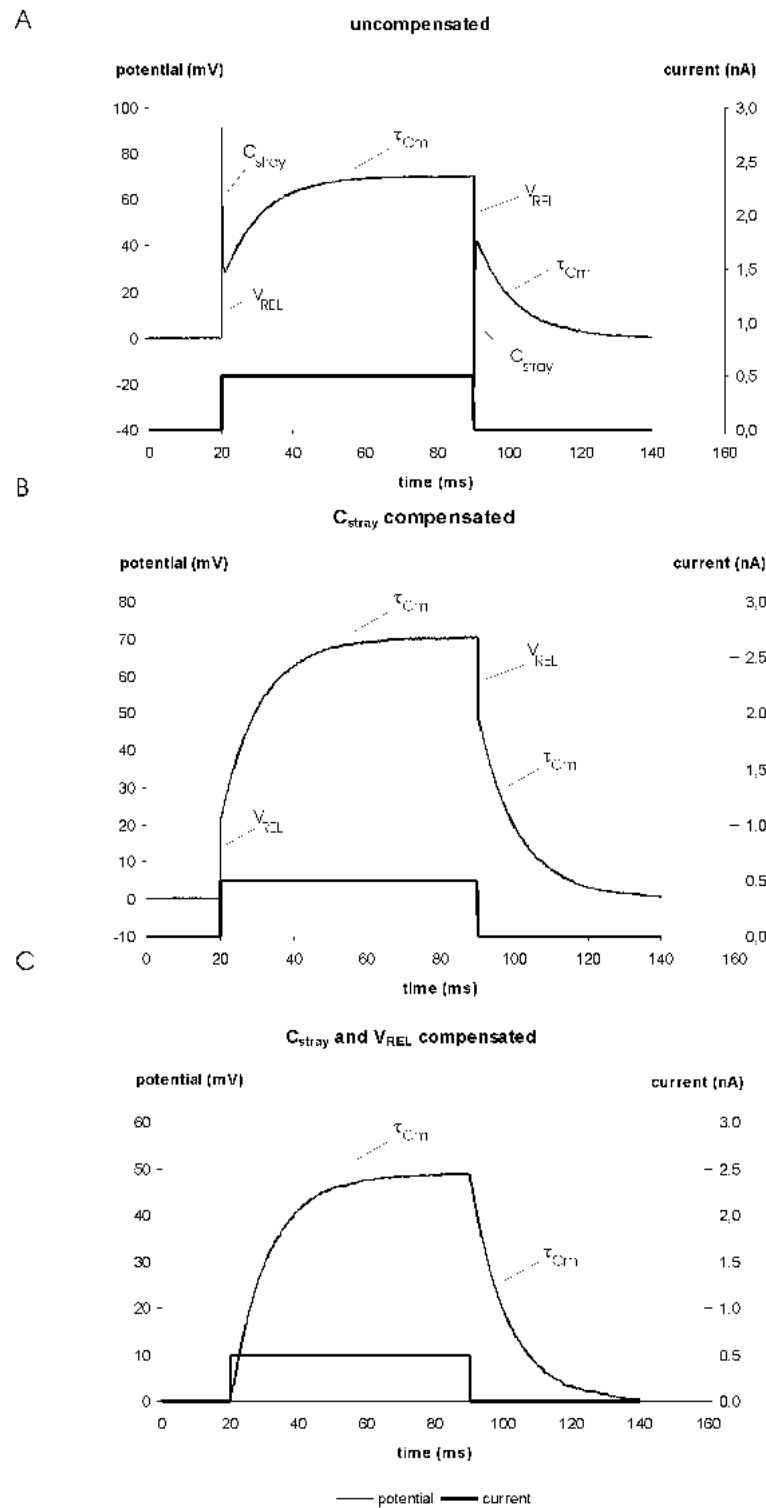

Figure 13: Artifacts caused by the recording electrode. The measurements were done using a cell model with 100 M Ω membrane resistance, 100 pF membrane capacitance and 100 M Ω electrode resistance.

A: C_{stray} and V_{REL} not compensated (bridge not balanced)

B: C_{stray}: compensated and V_{REL} not compensated

C: C_{stray} and V_{REL} compensated (bridge balanced)

C_m: membrane capacitance, C_{stray}: electrode stray capacitance, R_{EL}: electrode resistance, R_m: membrane resistance, τ_{Cm} : time constant of the cell membrane, V_{REL}: potential drop at R_{EL} (see also Figure 11)

8.2. Sample Experiment using a Suction (Patch) Electrode

If suction (patch) electrodes are used for whole cell recordings they are usually called “pipettes”. Thus, in this subchapter “pipette” means “suction electrode”.

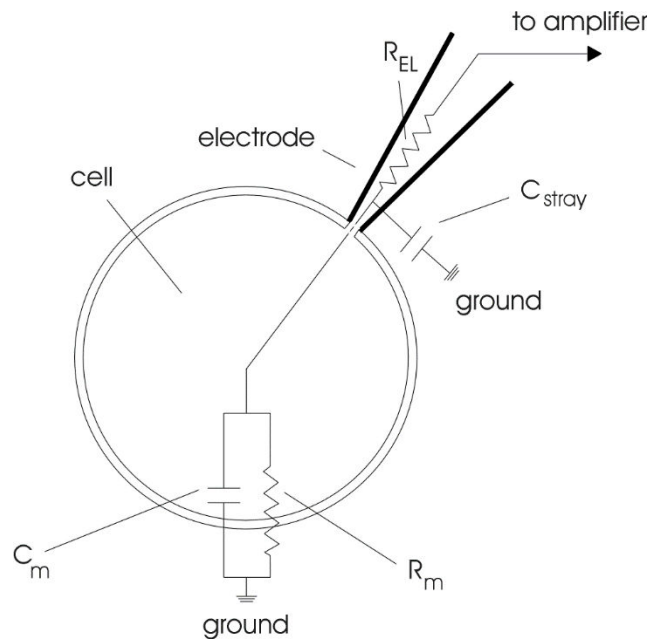

Figure 14: Model circuit for whole cell patch clamp recording using a suction electrode
 C_m : membrane capacitance, C_{stray} : electrode stray capacitance, R_{EL} : electrode resistance, R_m : membrane resistance

- o Prepare the setup and proceed as described in the previous subchapter (8.1) until you have selected a cell. Before immersing the pipette into the bath apply slight positive pressure to the pipette to prevent settling of particles at the tip.
- o Apply test pulses to the pipette (about 10 pA). The resulting voltage signals at the pipette are very small (50 μ V with a 5 M Ω electrode).
- o Approach the cell until the voltage signal changes (**a**, Figure 15). Often you can observe a slight dent in the cell membrane.
- o Release pressure from the pipette. Now forming of the seal is indicated by the voltage deflections getting much larger.
- o If the seal does not form apply gentle suction to the pipette until a gigaseal is established (**b**, Figure 15).
- o Apply stronger suction to the pipette or carefully use the BUZZ unit to brake the cell membrane under the pipette and establish the whole cell configuration. The whole cell configuration is established, if you see the voltage signal getting smaller again (**c**, Figure 15) and you read the expected membrane potential.
- o Read the membrane potential and if necessary, readjust the BRIDGE BALANCE as shown in 7.4 and Figure 13.
- o Start the experiment.

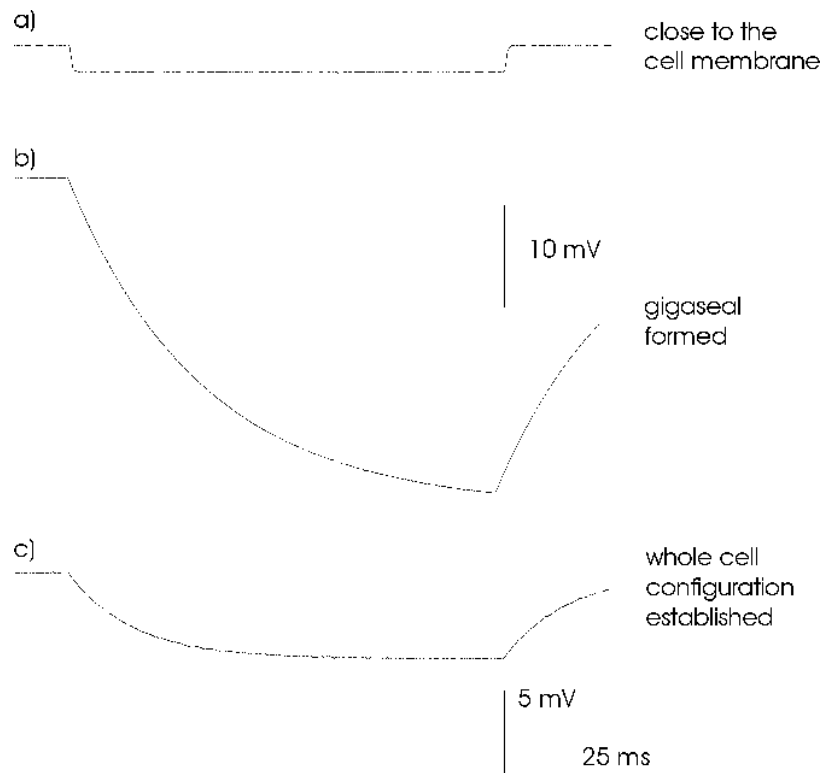

Figure 15: Approaching the cell, forming a gigaseal and establishing the whole cell configuration

8.3. Recordings with the Differential Headstage (optional)

Extracellular measurements are mostly done in slices or *in vivo*, in noisy environments, where distortions of the recorded signal caused by other instruments and the animal itself are very common. Additionally, extracellular signals are very small and have to be amplified enormously. The drawback is that noise is amplified as well. Therefore, the headstage of the BA-03X can be equipped with a differential input that minimizes noise pick-up. Differential means, that the signal for the amplifier is the difference between the positive (+) (P_{EL}) and negative (-) ($REF.$) input of the headstage. This results in canceling of all common mode signals (i.e. which both electrodes record, e.g. noise). For differential measurements, both inputs of the headstage ($REF.$ and P_{EL}) are connected to microelectrodes using cables with grounded enclosure or electrode holders. P_{EL} is connected to the measuring electrode and $REF.$ to the reference electrode. The experimental chamber is grounded by an Ag-AgCl pellet (or an AGAR bridge) connected to GND of the headstage (see Figure 16).

If differential measurement is not required (single-ended measurement configuration, see Figure 16), the $REF.$ input must be connected to ground (GND). The amplifier is in an undefined state, if the $REF.$ is left open, and can go into saturation making reliable measurements impossible (for more details see Lalley et al., 1999).

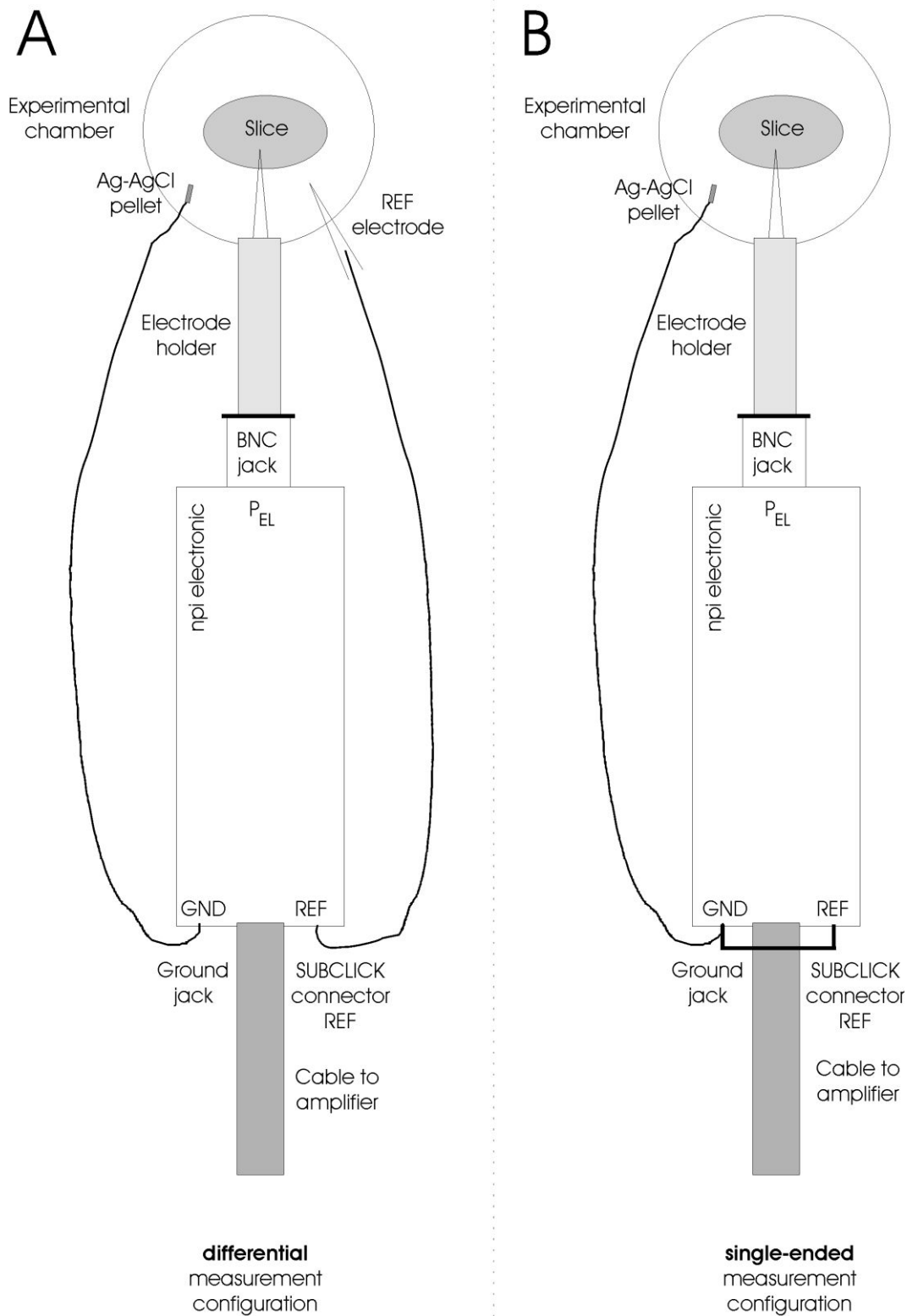

Figure 16: headstage connections, **A**: differential measurement, **B**: single-ended measurement

Differential measurements can also be done in intracellular recordings. The electrode connected to P_{EL} is inserted into a cell, and the reference electrode connected to REF is positioned outside the cell.

9. Trouble Shooting

In the following section some common problems, possible reasons and their solutions are described.

Important: Please note that the suggestions for solving the problems are only hints and may not work. In a complex setup it is impossible to analyze problems without knowing details. In case of trouble always contact an experienced electrophysiologist in your laboratory if possible, and connect a cell model to see whether the problem occurring with electrodes and “real” cells persists.

Problem 1:

After immersing the electrode into the bath there is an unusual high potential offset.

Possible reasons:

1. The Ag-AgCl coating of the silver wire in the electrode holder is damaged
2. The Ag-AgCl pellet or Ag-AgCl coating of the silver wire in the agar-bridge are damaged
3. There is an unwanted GND-bridge e.g. caused by a leaky bath
4. The headstage or the amplifier has an error

Solutions:

1. Chloride the silver wire again
2. Exchange the pellet or chloride the silver wire in the agar-bridge
3. Try to find the GND-bridge and disconnect it e.g. by sealing the bath
4. Contact npi

Problem 2:

Even if no stimulus is given a current flows through the electrode

Possible reason:

1. The BIAS current is not adjusted

Solution:

1. Adjust the BIAS current according the procedure described in chapter 7.1

Problem 3:

The system oscillates

Possible reason:

1. The capacitance of the electrode is overcompensated

Solution:

1. Turn the CAPACITY COMP. potentiometer (#17, Figure 1) to the most left position and compensate the input capacitance again

Problem 4:

With the cell model connected the R_{EL} display does not show the correct value (within a tolerance of 2%).

Possible reasons:

1. The capacitance of the electrode is not compensated (using the 100 M Ω electrode)
2. The headstage has an error

Solution:

1. Turn the CAPACITY COMP. potentiometer (#17, Figure 1) to the most left position and compensate the input capacitance again
2. Contact npi

Problem 5:

The amplifier does not provide any current.

Possible reason:

1. The OSCILLATION SHUT OFF circuit is on (LED #30, Figure 1 is red)

Solution:

1. Turn the CAPACITY COMP. potentiometer (#17, Figure 1) to the most left position and compensate the input capacitance again.
2. RESET the OSCILLATION SHUT OFF circuit using switch #32, Figure 1. LED #30, Figure 1 must become green.
3. Compensate the input capacitance again

10. Literature

Bridge amplifier recording

- o Behrend, O., Branoner, F., Zhivkov, Z., & Ziehm, U. (2006). Neural responses to water surface waves in the midbrain of the aquatic predator *Xenopus laevis laevis*. *Eur.J Neurosci.* **23**, 729-744.
- o Burrell, B. D. & Sahley, C. L. (2004). Multiple forms of long-term potentiation and long-term depression converge on a single interneuron in the leech CNS. *J Neurosci.* **24**, 4011-4019.
- o Burrell, B. D. & Sahley, C. L. (2005). Serotonin Mediates Learning-Induced Potentiation Of Excitability. *Journal of Neurophysiology* **94**, 4002-4010.
- o Gollisch, T., Schutze, H., Benda, J., & Herz, A. V. (2002). Energy integration describes sound-intensity coding in an insect auditory system. *J Neurosci.* **22**, 10434-10448.
- o Hutzler, M., Lambacher, A., Eversmann, B., Jenkner, M., Thewes, R., & Fromherz, P. (2006). High-resolution multi-transistor array recording of electrical field potentials in cultured brain slices. *J Neurophysiol.*
- o Kettenmann, H. & Grantyn, R. (eds.) (1992) *Practical Electrophysiological Methods*, Wiley-Liss, New York
- o **Lalley, P.M., A.K. Moschovakis and U. Windhorst (1999) Electrical Activity of Individual Neurons in Situ: Extra- and Intracellular Recording, in: U. Windhorst and H. Johansson (eds.) Modern Techniques in Neuroscience Research, Springer, Berlin, New York**
- o Maier, N., Nimmrich, V., & Draguhn, A. (2003). Cellular and network mechanisms underlying spontaneous sharp wave-ripple complexes in mouse hippocampal slices. *J Physiol* **550**, 873-887.
- o Mayer-Waarden, K. (1975) *Einführung in die biologische und medizinische Meßtechnik*. Schattauer-Verlag, Stuttgart.
- o Möck, M., Butovas, S., & Schwarz, C. (2006). Functional unity of the ponto-cerebellum: evidence that intrapontine communication is mediated by a reciprocal loop with the cerebellar nuclei. *J Neurophysiol.* **95**, 3414-3425.
- o Neher, E. (1974) *Elektrische Meßtechnik in der Physiologie*. Springer-Verlag, Berlin.
- o Nimmrich, V., Maier, N., Schmitz, D., & Draguhn, A. (2005). Induced sharp wave-ripple complexes in the absence of synaptic inhibition in mouse hippocampal slices. *Journal of Physiology* **563**, 663-670.

- o Ogden DC (1994) Microelectrode Techniques. The Plymouth Workshop Handbook, Second Edition, The Company of Biologists Limited, Cambridge
- o Prinz, A. A. and P. Fromherz (2000). Electrical synapses by guided growth of cultured neurons from the snail *Lymnaea stagnalis*, *Biol. Cybern.* 82, L1-L5
- o Prinz, A. A. & Fromherz, P. (2003). Effect of neuritic cables on conductance estimates for remote electrical synapses. *J Neurophysiol.* 89, 2215-2224.
- o Purves, R.D. (1981) Microelectrode Methods for Intracellular Recording and Ionophoresis. London: Academic Press
- o Rokem, A., Watzl, S., Gollisch, T., Stemmler, M., Herz, A. V., & Samengo, I. (2006). Spike-timing precision underlies the coding efficiency of auditory receptor neurons. *J Neurophysiol.* 95, 2541-2552.
- o Schaeffe, R., Gollisch, T., & Herz, A. V. M. (2005). Spike-Train Variability of Auditory Neurons in vivo: Dynamic Responses Follow Predictions from Constant Stimuli. *Journal of Neurophysiology* 93, 3270-3281.
- o Schoen, I. & Fromherz, P. (2007). The Mechanism of Extracellular Stimulation of Nerve Cells on an Electrolyte-Oxide-Semiconductor Capacitor. *Biophys.J.*, 92, 1096-1111.
- o Vogel, A., Hennig, R. M., & Ronacher, B. (2005). Increase of neuronal response variability at higher processing levels as revealed by simultaneous recordings. *Journal of Neurophysiology*, 93, 3548-3559.
- o Zeck G. and P. Fromherz (2001) Noninvasive neuroelectronic interfacing with synaptically connected snail neurons immobilized on a semiconductor chip, *PNAS*, Vol. 98, no. 18:10457–10462

Juxtosomal Filling, Loose-Patch Techniques (General)

- o Auger, C., & Marty, A. (2000). Topical Review: Quantal currents at single-site central synapses. *J Physiol.* 526.1, 3-11.
- o Barbour, B., & Isobe, P. (2000). Combining loose cell-attached stimulation and recording. *J Neurosci.Methods.* 103, 199–208.
- o Bureau, I., Shepherd, G. M. G. & Svoboda, K. (2004). Precise Development of Functional and Anatomical Columns in the Neocortex. *Neuron*, 42, 789-801.
- o Joshi, S. & Hawken, M. J. (2006). Loose-patch-juxtacellular recording in vivo-A method for functional characterization and labeling of neurons in macaque V1. *J Neurosci.Methods.* 156, 37-49.
- o Khaliq, Z. M., & Raman, I. M. (2005). Axonal Propagation of Simple and Complex Spikes in Cerebellar Purkinje Neurons. *J Neurosci.* 25, 454-463.
- o Klausberger, T., Marton, L. F., Baude, A., Roberts, J. D., Magill, P. J. & Somogyi, P. (2004). Spike timing of dendrite-targeting bistratified cells during hippocampal network oscillations in vivo. *Nature Neuroscience* 7, 41-47.
- o Nunemaker, C. S., DeFazio, R. A., & Moenter, S. M. (2003). A targeted extracellular approach for recording long-term firing patterns of excitable cells: a practical guide. *Biol.Proced.Online.* 5, 53-62. www.biologicalprocedures.com
- o Pinault, D. (1996). A novel single-cell staining procedure performed *in vivo* under electrophysiological control: morpho-functional features of juxtacellularly labeled thalamic cells and other central neurons with biocytin or Neurobiotin. *J Neurosci.Methods.* 65, 113-136.

- o Rathenberg, J., Nevian, T. & Witzemann, V. (2003). High-efficiency transfection of individual neurons using modified electrophysiology techniques. *J Neurosci.Methods*. **126**, 91-98.
- o Roberts, W. M., & Almers, W. (1992). Patch Voltage Clamping with Low-Resistance Seals: Loose Patch Clamp. In: Rudy, B. & Iversen, L. E. (eds.). *Ion Channels. Methods in Enzymology* **207**, Academic Press San Diego.
- o Strickholm, A. (1961). Impedance of a Small Electrically Isolated Area of the Muscle Cell Surface. *J Gen.Physiol.* **44**, 1073-1088.

Tracer injection (juxtosomal filling) and extracellular recording

- o Bruno, R. M. & Sakmann, B. (2006). Cortex is driven by weak but synchronously active thalamocortical synapses. *Science*. **312**, 1622-1627.

11. Technical Data

Headstage:

Input voltage range:	± 1000 mV
Operating voltage:	± 15 V
Enclosure:	Size: 23 x 70 x 26 mm, grounded
Holding bar:	Size: length 150 mm, \varnothing 8 mm
Electrode connector:	BNC with driven shield
Ground connector:	2.4 mm connector
REF connector (optional):	SMB connector
Input resistance:	$>10^{13}$ Ω (internally adjustable)
Current range x1:	± 12 nA into 1 G Ω
Current range x10:	± 120 nA into 100 M Ω

Electrode parameter controls:

BIAS:	range ± 150 pA (in x1 and x10 current range), current adjustable with trim potentiometer
OFFSET:	range ± 200 mV, ten-turn control
CAPACITY COMPENSATION:	range 0 – 30 pF, ten-turn control

Cell penetration:

overcompensation of capacitance compensation (BUZZ), duration ~ 2.5 – ~ 100 ms (dependent on the setting of capacitance compensation), timer controlled with linear control, accessible with remote switch

Electrode clear circuit:

Application of max. DC currents ($-I_{\max}$ or $+I_{\max}$)

Bridge balance:

Adjustable with ten-turn control and RANGE switch, 0-100 M Ω or 0-1000 M Ω

Electrode resistance test:

1 mV / M Ω obtained by application of square current pulses ± 1 nA, display XXXX M Ω

Bandwidth and speed response:

Full power bandwidth ($R_{EL} = 0$):	>30 kHz, rise time (10% - 90%) <10 μ s ($R_{EL} = 100$ M Ω) <5 μ s ($R_{EL} = 5$ M Ω)
--	---

Outputs:

Resistance:	50 Ω
Current:	BNC connector, sensitivity selectable by rotary switch 0.1, 0.2, 0.5, 1, 2, 5 or 10 V/ nA, display XX.XX nA (CURRENT RANGE: x1), display XXX.X nA (CURRENT RANGE: x10)
Potential:	BNC connector (POTENTIAL OUTPUT), sensitivity selectable by rotary switch (x10, x20, x50, x100, x200, x500, x1000), display XXXX mV or BNC connector (POTENTIAL OUTPUT FROM HEADSTAGE), sensitivity V/V
Potential LP filter:	4-pole BESSEL filter (other options available)
attenuation:	-24 dB/octave,
corner frequencies (Hz):	20, 50, 100, 200, 300, 500, 700, 1k, 1,3k, 2k, 3k, 5k, 8k, 10k, 13k, 20k
Potential HP filter:	1-pole filter, (other options available)
attenuation:	-6 dB/octave
corner frequencies (Hz):	DC, 0.1, 0.3, 0.5, 1, 3, 5, 10, 30, 50, 100, 300, 500, 800, 1k, 3k
Telegraph potential LP filter	-8...+7 V, 1V/step
Telegraph potential HP filter	-8...+7 V, 1V/step
Telegraph potential output sensitivity	+1...+7 V, 1 V/ step
Telegraph current output sensitivity	+1...+7 V, 1 V/ step

Inputs:

Current stimulus input via BNC connectors, sensitivity dependent on preset CURRENT RANGE

CURRENT RANGE x1: 1 nA / V or 0.1 nA / V

CURRENT RANGE x10: 10 nA / V or 1 nA / V

Step gate input via BNC connector, gated stimulus with digital control of current step size

Resolution x1: 10 pA

Resolution x10: 100 pA

Polarity selectable with toggle switch

Holding current range x1: ± 10 nA

Holding current range x10: ± 100 nA

Adjustable with ten-turn control

Dimensions:

19" rackmount cabinet

19" (483 mm), 10" (250 mm), 3.5" (88 mm)

Power requirements:

115/230 V AC, 60/50 Hz, fuse 0.4/0.2 A, slow, 25 W

Index

- abbreviations 3
- accessories 5
- AUDIO potentiometer 15
- basic settings 18
- bias current 34
- bias current adjustment 22
- BIAS current potentiometer 10
- bridge balance 25, 27, 29
- BRIDGE BALANCE unit 12
- CAPACITY COMP potentiometer 12
- cell model 19
 - connections and operation 20
 - description 19
- components 5
- CURRENT INPUT unit 13
- CURRENT OUTPUT unit 9
- CURRENT RANGE unit 10
- Differential Headstage (optional) 32
- electrical connections 18
- electrode 23
 - artifacts 30
 - capacity compensation 23
 - offset compensation 23
 - selection 26
- ELECTRODE
 - RESISTANCE TEST button 15
- front panel view 7
- gated stimulus unit 14
- general description 5
- GROUND connector 15
- headstage 17
 - elements 17
 - HEADSTAGE connector 12
- HOLDING CURRENT unit 10
- literature 35
- model circuit sharp electrode 28
- model circuit suction (patch) electrode 31
- OFFSET potentiometer 11
- OSCILLATION SHUT-OFF unit 15
- PENETRATION unit 11
- POTENTIAL OUTPUT unit 8
- rear panel 16
- safety regulations 4
- sample experiments 28
 - sharp electrode 28
 - suction (patch) electrode 31
- seal formation 32
- sharp electrodes 28
- suction (patch) electrodes 31
- technical data 38
- testing 22
- trouble shooting 34
- tuning 22