

made to measure

OPERATING INSTRUCTIONS AND SYSTEM DESCRIPTION FOR THE

LHBF-48X

AMPLIFIER / FILTER SYSTEM



VERSION 2.5
npi 2026

npi electronic GmbH, Bauhofring 16, D-71732 Tamm, Germany
Phone +49 (0)7141-9730230; Fax: +49 (0)7141-9730240
support@npielectronic.com; <http://www.npielectronic.com>

Table of Contents

1. Safety Regulations	3
2. LHBF-48X Components.....	4
3. LHBF-48X Amplifier / Filter	4
3.1. System Description.....	4
3.2. Signal Flow Diagram.....	4
3.3. Description of the Front Panel and Operation	5
3.4. Description of the Rear Panel	9
4. Literature.....	9
5. Technical Data	10

1. Safety Regulations

VERY IMPORTANT: Instruments and components supplied by npi electronic are NOT intended for clinical use or medical purposes (e.g. for diagnosis or treatment of humans), or for any other life-supporting system. npi electronic expressly disclaims any warranties for such purpose. Equipment supplied by npi electronic shall be operated only by selected, trained and adequately instructed personnel. For details please consult the GENERAL TERMS OF DELIVERY AND CONDITIONS OF BUSINESS of npi electronic, D-71732 Tamm, Germany.

- 1) **GENERAL:** This system is designed for use in scientific laboratories and should be operated by trained staff only. General safety regulations for operating electrical devices should be considered.
- 2) **AC MAINS CONNECTION:** While working with the npi systems, always adhere to the appropriate safety measures for handling electronic devices. Before using any device please read manuals and instructions carefully.
The device is to be operated only at 115/230 Volt 60/50 Hz AC. Please check for appropriate line voltage before connecting any system to mains.
Always use a three-wire line cord and a mains power-plug with a protection contact connected to ground (protective earth).
Before opening the cabinet, disconnect mains power-plug.
Disconnect mains power-plug when replacing the fuse or changing line voltage. Replace fuse only with an appropriate specified type.
- 3) **STATIC ELECTRICITY:** Electronic equipment is sensitive to static discharges. Some devices such as sensor inputs are equipped with very sensitive FET amplifiers, which can be damaged by electrostatic charge and must therefore be handled with care. This can be avoided by touching a grounded metal surface when changing or adjusting sensors. **Always turn power off when adding or removing modules, connecting or disconnecting sensors, headstages or other components from the instrument or 19" cabinet.**
- 4) **TEMPERATURE DRIFT / WARM-UP TIME:** All analog electronic systems are sensitive to temperature changes. Therefore, all electronic instruments containing analog circuits should be used only in a warmed-up condition (i.e. after internal temperature has reached steady-state values). In most cases a warm-up period of 20-30 minutes is sufficient.
- 5) **HANDLING:** Please protect the device from moisture, heat, radiation and aggressive chemicals.

2. LHBF-48X Components

The following items are shipped with the LHBF-48X amplifier / filter:

- LHBF-48X 19” cabinet
- Power cord
- User manual

3. LHBF-48X Amplifier / Filter

3.1. System Description

The LHBF-48X amplifier/filter is designed for processing small bio-electrical signals. The input voltage range is ± 12 V. Two overload-LEDs indicate that the amplifier is going to leave its linear range (± 12 V), i.e. that the OUTPUT voltage exceeds ± 10 V. All inputs and outputs are BNC connectors.

The unit is equipped with a differential input stage with an AC / 0 / DC switch for each input. The input stage is followed by the offset compensation (see Figure 1).

The GAIN stage allows amplification of the signal from 1-1000 in 1-2-5 steps. The GAIN is selected by a 10-position rotary switch.

The amplified signal is passed through the HIGHPASS (optional) and LOWPASS filter. The four-pole or eight-pole Bessel LOWPASS FILTER has sixteen corner frequencies (20 Hz – 20 kHz). The LOWPASS FILTER can also be bypassed by using a toggle switch.

The one-pole HIGHPASS FILTER has fifteen corner frequencies (0.1 Hz - 3 kHz) and a DC position.

The OFFSET is indicated by an analog meter (range ± 300 mV). The OFFSET cancellation range is ± 0.1 V to ± 10 V. The OFFSET is cancelled by setting two controls, a ten-turn potentiometer and a ± 0.1 V, ± 1 V, ± 10 V range switch.

DC offsets can be compensated either by using the OFFSET control or they can be eliminated using the AC position of the input switches or by using the HIGHPASS filter.

The positions of GAIN and FILTER switches can be read from monitor outputs (1 V/step).

3.2. Signal Flow Diagram

The signal is passed through the LHBF-48X as shown below:

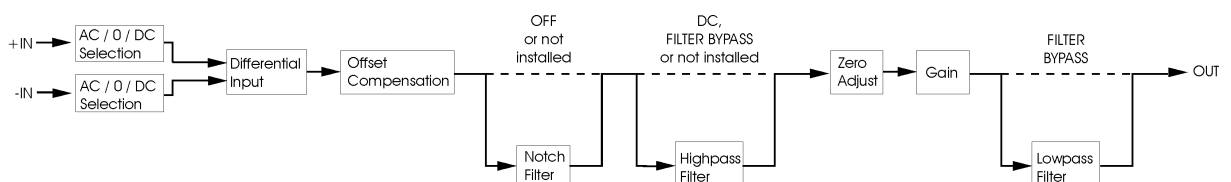

Figure 1: signal flow diagram

3.3. Description of the Front Panel and Operation

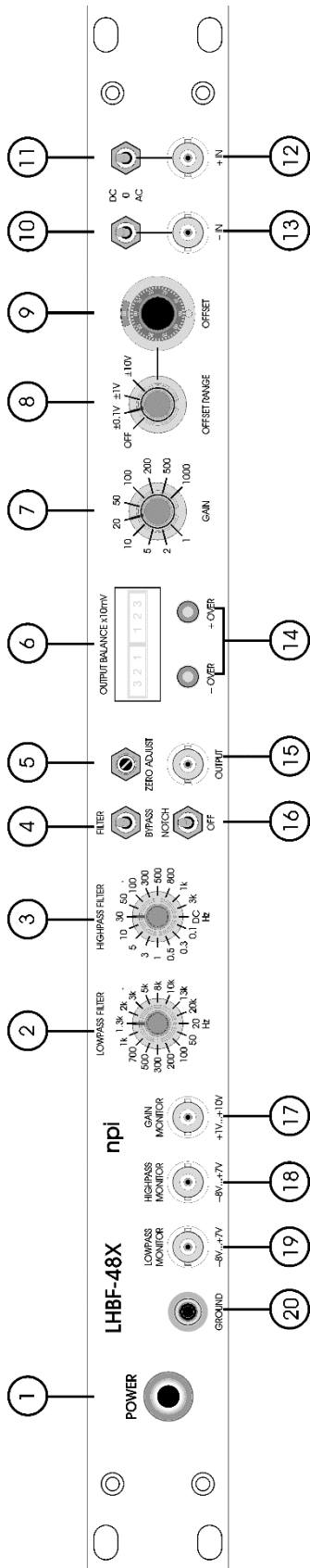

Figure 2: LHBF-48X front panel view (the numbers are related to those in the text below)

In the following description of the front panel elements each element has a number that is related to that in Figure 2. The number is followed by the name (in uppercase letters) written on the front panel and the type of the element (in lowercase letters). Then, a short description of the element is given. Some elements are grouped in functional units (e.g. INPUT unit) and are described as units regardless of the order of numbers.

(1) POWER pressure switch



Switch to turn POWER on (switch pushed) or off (switch released).

FILTER unit



The filter unit consists of **(2)** HIGHPASS filter and **(3)** LOWPASS filter.

(2) LOWPASS filter rotary switch

LOWPASS Bessel filter with -24 dB/octave (four-pole version) or -48 dB/octave (eight-pole version). Corner frequencies: 20, 50, 100, 200, 300 500, 700, 1k, 1.3k, 2k, 3k, 5k, 8k, 10k, 13k, 20k Hz.

(3) HIGHPASS FILTER rotary switch

Single pole HIGHPASS filter with 6 dB / octave. Corner frequencies: 0.1, 0.3, 0.5, 1, 3, 5, 10, 30, 50, 100, 300, 500, 800, 1k, 3k Hz. In DC position the filter is disabled.

(4) FILTER switch



Switch to set the LOWPASS and HIGHPASS FILTER (switch position FILTER) or to bypass both FILTERS (switch position BYPASS).

(5) ZERO ADJUST potentiometer



Potentiometer to compensate for internal offsets before the signal goes into gain stage (see Figure 1).

(6) OUTPUT BALANCE monitor

This analog monitor is no longer part of the instrument.

(7) GAIN rotary switch



10-position rotary switch to set the amplification factor of the incoming signal (range: 1 to 1000).

OFFSET unit



The OFFSET unit consists of OFFSET RANGE rotary switch (8) and OFFSET potentiometer (9).

(8) OFFSET RANGE rotary switch

4-position rotary switch to set the RANGE of the OFFSET potentiometer (#9) (OFF, ± 0.1 V, ± 1 V, ± 10 V).

(9) OFFSET potentiometer

10-turn potentiometer to compensate for the OFFSET of a DC signal. The OFFSET range is set by a switch (#11).

Note: Position 5 of the OFFSET control corresponds to 0 mV OFFSET. The offset compensation only works if the input coupling switch (#10, #11) is set to DC and the HIGHPASS FILTER (#2) is set to OFF.

INPUT unit

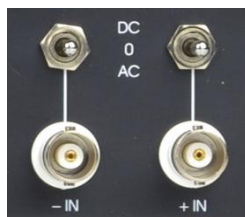

The input coupling unit consists of input coupling switches (10, 11) and input connectors (12, 13).

The position of the input coupling switches decides how the input signals are coupled:

AC: the input signal is AC coupled with a corner frequency of 0.1 Hz, e.g. DC offsets were cancelled

DC: the input signal is DC coupled

0: the input signal is grounded

(10) DC / 0 / AC switch

Switch to select the coupling of an incoming signal (AC or DC) for -IN. Position 0 links the respective INPUT connector (#13) to ground.

(11) DC / 0 / AC switch

Switch to select the coupling of an incoming signal (AC or DC) for +IN. Position 0 links the respective INPUT connector (#12) to ground.

(12) +IN connector

BNC connector to connect the signal to be processed.

(13) -IN connector

BNC connector to connect the signal to be processed.

The INPUTS can be used in single-ended or differential configuration. For single-ended operation connect the signal to be processed to the +IN or –IN connector and set the other (not used) input to ground using the respective toggle switch (set #11 or #12 to 0 position). In differential configuration the signal that is connected to –IN is subtracted from the signal that is connected to +IN.

Important: If only one INPUT is used (single-ended configuration), the other should be linked to ground (see also #10, #11) to avoid coupling of noise.

(14) +/- OVER LEDs



Two overload-LEDs indicating that the amplifier is going to leave its linear range (± 12 V), i.e. that the OUTPUT voltage exceeds ± 10 V.

(15) OUTPUT connector



BNC connector providing the processed signal.

(16) NOTCH FILTER switch (optional)

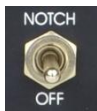

Switch to set the NOTCH FILTER (50 Hz / 60 Hz) (switch position NOTCH FILTER) or to bypass the NOTCH FILTER (switch position OFF).

(17) GAIN MONITOR connector



BNC connector monitoring the position of the GAIN switch (+1V...+10V, 1V / step).

(18) HIGHPASS MONITOR connector



BNC connector monitoring the position of the HIGHPASS FILTER switch (-7V...+8, 1V / step).

(19) LOWPASS MONITOR connector



BNC connector monitoring the position of the LOWPASS FILTER switch (-7V...+8V, 1V / step).

(20) GROUND connector



Banana plug for grounding. This connector is linked to the internal system ground which has no connection to the 19" cabinet and the mains ground to avoid ground loops.

3.4. Description of the Rear Panel

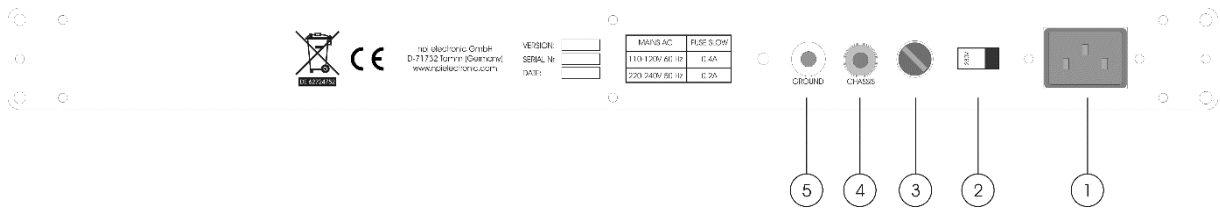

Figure 3: LHBF-48X rear panel view (the numbers are related to those in the text below)

(1) Mains connector

Connector for mains.

(2) Voltage selector

Turning knob for selecting the mains voltage, 115 V or 230 V.

Important: Switch always to the appropriate mains voltage before connecting the filter to mains.

(3) Fuse selector

Turning knob for the fuse holder. Turn counterclockwise to open.

Important: Use always the appropriate fuse for the present mains voltage before connecting the filter to mains (230 V / 0.2 A; 115 V / 0.4 A, slow).

(4) Chassis connector

This banana jack is linked to the chassis. It can be used for grounding the housing of the LHBF-48X.

(5) Ground connector

This banana jack is linked to the internal system ground which has no connection to the 19" cabinet and to mains ground to avoid ground loops.

4. Literature

- Kettenmann, H. & Grantyn, R. (eds.) (1992) Practical Electrophysiological Methods, WileyLiss, New York
- Ogden DC (1994) Microelectrode Techniques. The Plymouth Workshop Handbook
- Second Edition, The Company of Biologists Limited, Cambridge
- Tietze, U and Ch. Schenk (1999) Halbleiter-Schaltungstechnik (Semiconductor Techniques) 11. Edition, Springer, Berlin, Heidelberg, New York [English version available].
- Windhorst, U. and H. Johansson (eds.) (1999) Modern Techniques in Neuroscience Research, Springer, Berlin, Heidelberg, New York

5. Technical Data

Input:

Input range:	± 12 V
Input impedance:	10k Ω
AC-coupling at input:	Corner frequency of 0.1 Hz
Differential input:	CMR >90 dB

Output:

Full power bandwidth:	20 kHz
Range of output:	max. ± 12 V
Output impedance:	50 Ω
Overload LED threshold:	± 10 V
Gain monitor:	1V/switch step, +1V...+10V
Frequency monitors:	1V/switch step, -8V...+7V

Lowpass filter:

Filter type:	4-pole or 8-pole Bessel filter
Attenuation:	-24 dB/octave (4-pole) or -48 dB/octave (8-pole)
Corner frequencies (Hz):	20, 50, 100, 200, 300 500, 700, 1k, 1.3k, 2k, 3k, 5k, 8k, 10k, 13k, 20k Hz

Highpass filter:

Filter type:	single pole filter
Attenuation:	-6 dB / octave
Corner frequencies (Hz):	DC, 0.1, 0.3, 0.5, 1, 3, 5, 10, 30, 50, 100, 300, 500, 800, 1k, 3k Hz

Gain:

Ten steps:	1, 2, 5, 10, 20, 50, 100, 200, 500, 1000
------------	--

Offset compensation:

Three ranges:	± 0.1 V, ± 1 V or ± 10 V
---------------	--------------------------------------

Power requirements:

19" rackmount cabinet:	230V/115V AC, 20 W, fuse 0.2A/0.4A, slow
------------------------	--