

OPERATING INSTRUCTIONS AND SYSTEM DESCRIPTION FOR THE

PEXT-01

PNEUMATIC DRUG EJECTION SYSTEM AND EXTRACELLULAR AMPLIFIER



VERSION 1.1
npi 2010

npi electronic GmbH, Hauptstrasse 96, D-71732 Tamm, Germany
Phone +49 (0)7141-9730230; Fax: +49 (0)7141-9730240
support@npielelectronic.com; <http://www.npielectronic.com>

Table of Contents

1. Safety Regulations.....	3
2. PEXT-01 System.....	4
2.1. System Description.....	4
2.2. Description of the Front Panel.....	5
Pressure Ejection Elements	6
Extracellular Recording Elements	7
2.3. Description of the Rear Panel.....	10
2.4. External Valves (Option).....	11
Remote Valve Plate	11
microJECT micro Valve Pipette Holder.....	11
2.5. Headstage (Option).....	12
Headstage Elements.....	12
3. Operation	13
3.1. Pressure Ejection	13
3.2. Extracellular Recording	15
4. Literature	17
4.1. Pressure Ejection	17
4.2. Extracellular Recording	18
5. Technical Data.....	19
5.1. Pressure Ejection	19
5.2. Extracellular Recording	20

1. Safety Regulations

VERY IMPORTANT: Instruments and components supplied by npí electronic are **NOT** intended for clinical use or medical purposes (e.g. for diagnosis or treatment of humans), or for any other life-supporting system. npí electronic disclaims any warranties for such purpose. Equipment supplied by npí electronic must be operated only by selected, trained and adequately instructed personnel. For details please consult the **GENERAL TERMS OF DELIVERY AND CONDITIONS OF BUSINESS** of npí electronic, D-71732 Tamm, Germany.

- 1) **GENERAL:** This system is designed for use in scientific laboratories and must be operated by trained staff only. General safety regulations for operating electrical devices should be followed.
- 2) **AC MAINS CONNECTION:** While working with the npí systems, always adhere to the appropriate safety measures for handling electronic devices. Before using any device please read manuals and instructions carefully.
The device is to be operated only at 115/230 Volt 60/50 Hz AC. Please check for appropriate line voltage before connecting any system to mains.
Always use a three-wire line cord and a mains power-plug with a protection contact connected to ground (protective earth).
Before opening the cabinet, unplug the instrument.
Unplug the instrument when replacing the fuse or changing line voltage. Replace fuse only with an appropriate specified type.
- 3) **STATIC ELECTRICITY:** Electronic equipment is sensitive to static discharges. Some devices such as sensor inputs are equipped with very sensitive FET amplifiers, which can be damaged by electrostatic charge and must therefore be handled with care. Electrostatic discharge can be avoided by touching a grounded metal surface when changing or adjusting sensors. **Always turn power off when adding or removing modules, connecting or disconnecting sensors, headstages or other components from the instrument or 19" cabinet.**
- 4) **TEMPERATURE DRIFT / WARM-UP TIME:** All analog electronic systems are sensitive to temperature changes. Therefore, all electronic instruments containing analog circuits should be used only in a warmed-up condition (i.e. after internal temperature has reached steady-state values). In most cases a warm-up period of 20-30 minutes is sufficient.
- 5) **HANDLING:** Please protect the device from moisture, heat, radiation and corrosive chemicals.

HIGH PRESSURE PRECAUTIONS: While working with PEXT systems and components, always adhere to the appropriate safety measures for handling high pressure pneumatic systems. Before using the PEXT or any external pneumatic device please read the manual and instructions carefully.

- Always turn off pressure source before connecting or disconnecting the PEXT system.
- Any component used (tubes, fittings etc.) must be specified for the maximum possible pressure.
- Do not use any aggressive, combustible or explosive gases. Only gases such as air, nitrogen, carbon dioxide, helium, etc. are allowed.
- Use only dry, oil free, filtered gases (max. 5 µm filter is allowed).
- Maximum input pressure must be below 5 bar (1 bar = 100,000 Pa). npí recommends an input pressure of 1 bar more than the maximum output pressure.

2. PEXT-01 System

2.1. System Description

Pressure ejection is a convenient method for applying both ionic and non-ionic solutions from micropipettes. This method is popular for two reasons. First, it can apply to almost all solutions. Second, the amount of solution ejected can be monitored by viewing the tip of the micropipette under a microscope.

In several experimental situations not only drug application but also extracellular recording is required. Therefore, npI combines the one channel drug ejection system (PDES) with an extracellular amplifier (EXT) resulting in the PEXT-01 system.

The PEXT-01 is designed for pressure ejection of drugs in physiological and pharmacological studies while recording extracellular signals. The PDES part equipped with a high pressure output ($P_{\max} = 2 \text{ bar} / 29 \text{ psi}$ or $4 \text{ bar} / 58 \text{ psi}$) for drug application with fine-tipped micropipettes, but can also be operated in low-range pressure for controlled droplet application from large-tipped pipettes. A digital timer and a remote control unit (optional) facilitate the use of these instruments.

In order to speed up drug ejection, PEXT systems are also available with the *microJect* option. These systems are equipped with a micro valve located in an injection holder. The micro valve has a switch time of less than 1 ms and a very small volume that has to be controlled, resulting in application times in the ms range.

The PEXT-01 is housed in a 19" cabinet that can be mounted in a rack. It comprises of one pressure ejection channel and one extracellular recording channel. The pressure ejection channel consists of a precision pressure regulator, a digital pressure display, electronically controlled valves, control electronics and a regulated power supply. Ejection of drugs can be activated manually or via a TTL input. The operational status is indicated by a red/green LED. The pressure output is monitored at a BNC output (1V / bar or 0.1V / psi) and additionally the signal for pressure control is available via TTL OUT BNC connector.

Mode of operation and timing is selected by controls at the front panel. If the internal timer is used, the eject time is preset by a digital control. The operational status is indicated by a red/green LED. Red means that the channel has been turned on and the valve is closed, green indicates that the valve is open and injection takes place.

The pressure connectors (quick connect type) are located at the rear panel of the instrument. The pressure ejection channel is equipped with an INPUT coupling where the pressure source is connected, an OUTPUT coupling where the injection pipette or the external valve is connected.

The injection pressure is preset by a precision pressure regulator. The pressure is displayed on a digital manometer. Additional pneumatic devices (tubes, fittings connectors, filters etc.) are available. Please contact npI electronic for details. A calibration procedure allowing quantitative drug application is described by Hofmeier and Lux (1981).

The EXT part of the PEXT-01 is designed for extracellular recordings of small voltage signals. It has a differential input with high input impedance to avoid noise. The output voltage signal can be HIGH or LOW PASS filtered, and is available either AC (HIGH PASS filtered) or DC coupled with variable gain.

Two LEDs indicate whether the amplifier is running out of its linear range, and an analog balance monitor makes the control of OFFSETS easy. A built-in audio speaker monitors the output signal of one channel (A or B). A THRESHOLD function (in NOISE mode) can be used for masking the noise of the baseline. A phone jack allows connection of an external speaker (HEAD PHONES) or further audio amplification, e.g. computer sound card, active speakers, power amplifier etc.

2.2. Description of the Front Panel

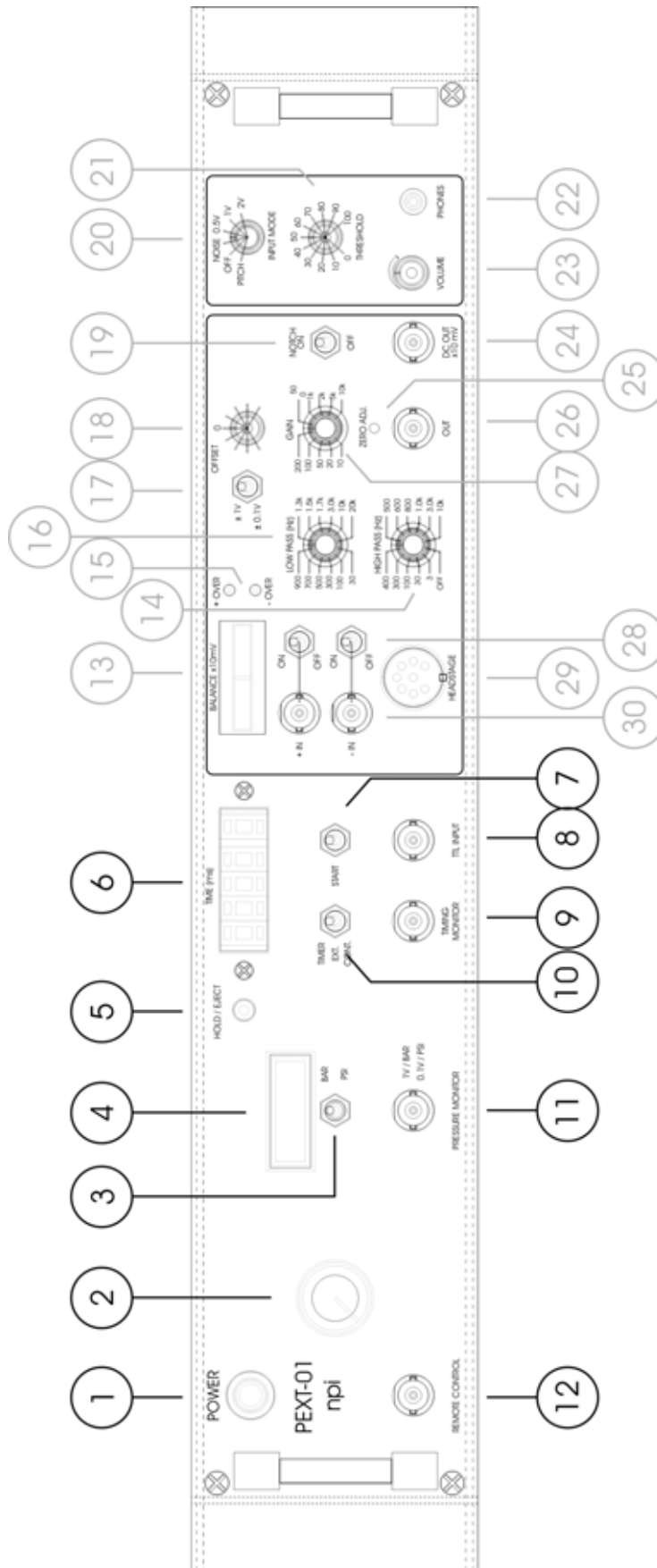

Figure 1: PEXT-01 front panel view (the numbers are related to those in the text below)

In the following description of the front panel elements, each element has a number that is related to that in Figure 1. The number is followed by the name (in uppercase letters) written on the front panel and the type of the element (in lowercase letters). Then, a short description of the element is given.

Pressure Ejection Elements

(1) POWER push button

Push button to turn POWER on or off

(2) Pressure regulator

Rotary knob for regulating the pressure

(3) BAR / PSI switch

Switch to select the unit of the reading of the display (**#4**) and the output at PRESSURE MONITOR (**#11**)

(4) Manometer

Digital display for the pressure (X.XX bar or XXX.X psi)

(5) Operation LED

Indicates the operational status

red light: channel has been turned on, valve is closed

green light: valve is open or valve not connected

(6) TIME (ms) tumble-wheel switch

Five digit tumble-wheel switch to set the ejection time (XXXX.X ms) in TIMER mode

(7) START button

Push button to start operation. The START button can be used to start ejection in TIMER or EXT. mode.

In TIMER mode pressing the START button opens the valve for the time set by **#6**.

In EXT. mode pressing the START button opens the valve as long as the button is pressed

(8) TTL INPUT connector

BNC connector for external operation

In TIMER mode a TTL HI (+5V) signal opens the valve for the time set by **#6**.

In EXT. mode a TTL HI (+5V) signal opens the valve as long as the signal level is HI

(9) TIMING MONITOR connector

BNC connector providing a TTL signal that indicates the status of the regulated injection valve (HI = valve open, LO = valve closed)

(10) TIMER, EXT., CONT. switch

Switch to set the operation mode (see also chapter 3.1)

(11) PRESSURE MONITOR connector

BNC connector monitoring the pressure output, sensitivity: 1 V / bar or 0.1 V / psi, respectively

(12) REMOTE CONTROL connector

Connector for the REMOTE CONTROL push button (optional)

Extracellular Recording Elements

(13) BALANCE x10mV meter

The analog BALANCE monitor displays the OFFSET in the range of ± 30 mV and is used for optimal cancellation of the OFFSET.

(14) HIGHPASS (Hz) switch

12-position switch for selecting the corner frequency of the single pole HIGHPASS filter with -6 dB / octave. In OFF position the HIGHPASS filter is disabled (DC recording).

Corner frequencies (Hz): 3, 30, 100, 300, 400, 500, 600, 800, 1k, 3k, 10k.

Note: A combination of both LOWPASS and HIGHPASS FILTER leads to a filter with bandpass characteristics.

(15) + / - OVERLOAD LEDs

LEDs that indicate if the amplifier works at 10% below its positive or negative limit. The linear range of the amplifier is ± 12 V.

(16) LOWPASS (Hz) switch

12-position switch for selecting the corner frequency of the single pole LOWPASS filter with -6 dB / octave. Corner frequencies: 30, 100, 300, 500, 700, 900, 1.3k, 1.5k, 1.7k, 3k, 10k, 20k Hz.

Note: A combination of both LOWPASS and HIGHPASS FILTER leads to a filter with bandpass characteristics.

(17) OFFSET range switch

Switch to set the range for the OFFSET potentiometer (**#18**).

± 1 V corresponds to a range from 0 mV to 1000 mV at the electrode

± 0.1 V corresponds to a range from 0 mV to 100 mV at the electrode

(18) OFFSET potentiometer

Potentiometer for OFFSET compensation for the measured potential in DC mode. The RANGE is set by switch **#17**. The analog BALANCE monitor (**#13**) displays the OFFSET in the range of ± 30 mV, and can be used for optimal cancellation of the OFFSET.

Note: The middle position corresponds to 0 V OFFSET since negative as well as positive OFFSETS can be cancelled.

(19) NOTCH ON / OFF switch (optional)

Switch that enables (upper position) or disables (lower position) the NOTCH filter (optional).

Audio Monitor**(20) INPUT MODE switch**

Switch for selecting the INPUT MODE.

PITCH: The voltage of the INPUT signal is converted into a tone with a frequency equivalent to the amplitude of the INPUT voltage.

OFF: The audio monitor is switched OFF

NOISE: The voltage of the INPUT signal is high pass filtered, amplified and transduced to a sound.

2 V, 1 V, 0.5 V: The audio monitor works in NOISE MODE with THRESHOLD function. 100% THRESHOLD is set to the selected value (2 V, 1 V or 0.5 V) (see also #21).

(21) THRESHOLD % potentiometer

Potentiometer for setting the THRESHOLD in % of the value set by INPUT MODE switch #20 (0.5 V, 1 V, 2 V). For example, if the INPUT MODE switch #20 is set to 2 V and the THRESHOLD potentiometer is set to 50%, the resulting THRESHOLD for monitoring the OUTPUT signal will be at 1 V, i.e. only signals greater than 1 V will be converted into a sound (NOISE). With an amplification of 10000 this corresponds to a signal of 100 μ V at the electrode.

(22) PHONES connector

Stereo jack connector for PHONES or an external amplifier (e.g. active speakers).

(23) VOLUME potentiometer

Potentiometer for setting the VOLUME of the internal speaker or PHONES linked to connector #22. Turning clockwise will turn up the sound.

(24) DC OUT x10mV connector

BNC connector providing the measured DC signal with a fixed amplification of 10 (optional). This signal is not filtered. Use of this connector allows, for instance, measuring the signal AC (signal is provided at #26) while watching the offset simultaneously.

(25) ZERO ADJ. trimpot

Trimpot to compensate for amplifier offsets. If the baseline is not zero even if the input is grounded (INPUT switches #28 set to OFF), this offset can be compensated. Compensation procedure:

- Set the input switches (#28) to OFF to ground the inputs, and set the HIGH PASS FILTER to 400 Hz.
- Set the GAIN range switch to 1k and adjust the baseline to zero using the trimpot.
- Set the GAIN range switch to 10k and adjust the baseline again if necessary.

(26) OUTPUT connector

BNC connector providing the recorded and conditioned signal.

(27) GAIN switch

10-position switch for selecting the GAIN of the output signal at the OUTPUT connector (#26). Amplification factors: x10, x20, x50, x100, x200, x500, x1k, x2k, x5k, x10k.

(28) INPUT switches

Switches for grounding the INPUT connectors (#30) or the headstage connector (#29). One switch for the + IN and one for the –IN

Important: In differential measurements both switches for + IN and – IN have to be in the same position. In single-ended measurements the switch for the INPUT that is not used must be set to OFF!! (see also chapter 3.2).

(29) HEADSTAGE connector

Connector for the **optional** headstage (see also chapter 2.5).

(30) -IN, +IN connectors

BNC connectors for connecting the INPUT signal if no headstage is used. The inputs can be used in single ended or differential configuration. In differential configuration the signal which is connected to –IN is subtracted from the signal that is connected to +IN. Usually the reference electrode is connected to the –IN connector. If only one INPUT is used (single ended configuration) the other INPUT must be grounded using switch #28 (see also #28 and chapter 3.2).

Very Important: You **must not** use inputs at the front panel and a headstage simultaneously!! If the BNC connectors are used the headstage must be disconnected.

2.3. Description of the Rear Panel

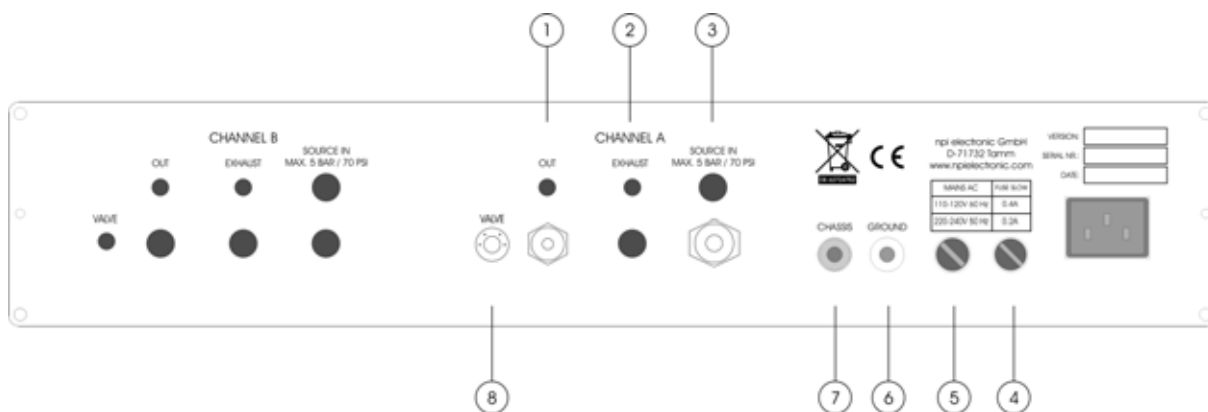

Figure 2: PEXT-01 rear panel view (the numbers are related to those in the text below)

The following connectors are located at the rear panel.

(1) OUT connector

Connector for connecting the ejection pipette. The EJECT pressure is supplied to this connector.

(2) EXHAUST connector

Not installed.

(3) SOURCE IN connector

Connector for connecting the filtered, dry and oil-free gas source (5 bar max.).

Note: npi recommends an input pressure of 1 bar more than the maximum output pressure.

(4) FUSE

Unplug the instrument when replacing the fuse or changing line voltage. Turn knob to open. Replace fuse only with an appropriate specified type (see chapter 5)

(5) Voltage SELECTOR

Rotary switch for selecting the operating voltage (115 V / 230 V).

Caution: Always switch to the appropriate voltage before connecting the PEXT-01 to mains.

(6) GROUND

This connector is linked to the internal system ground which has no connection to the 19" cabinet (CHASSIS) and the mains ground to avoid ground loops.

(7) CHASSIS

This connector is linked to mains ground (green / yellow wire, protective earth).

(8) VALVE connector

Connector for the electrical connection of the VALVE located in a remote valve box or in the *microJECT*.

2.4. External Valve (Option)

An external valve for the PEXT-01 system is either mounted on a remote valve plate or in the *microJECT* micro valve pipette holder.

Remote Valve Plate

The valve that is controlled by the PEXT-01 is located on the remote valve plate (see Figure 3). Tubing and cable of the external valve are connected at the rear panel of the PEXT-01 system (refer to chapter 2.3). Exhaust is usually not connected.

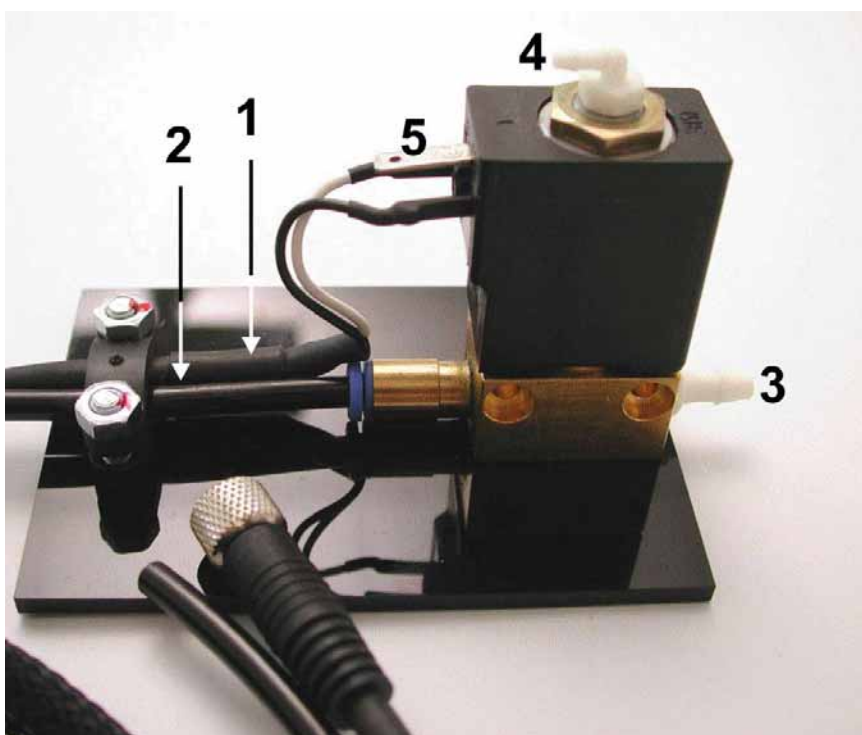
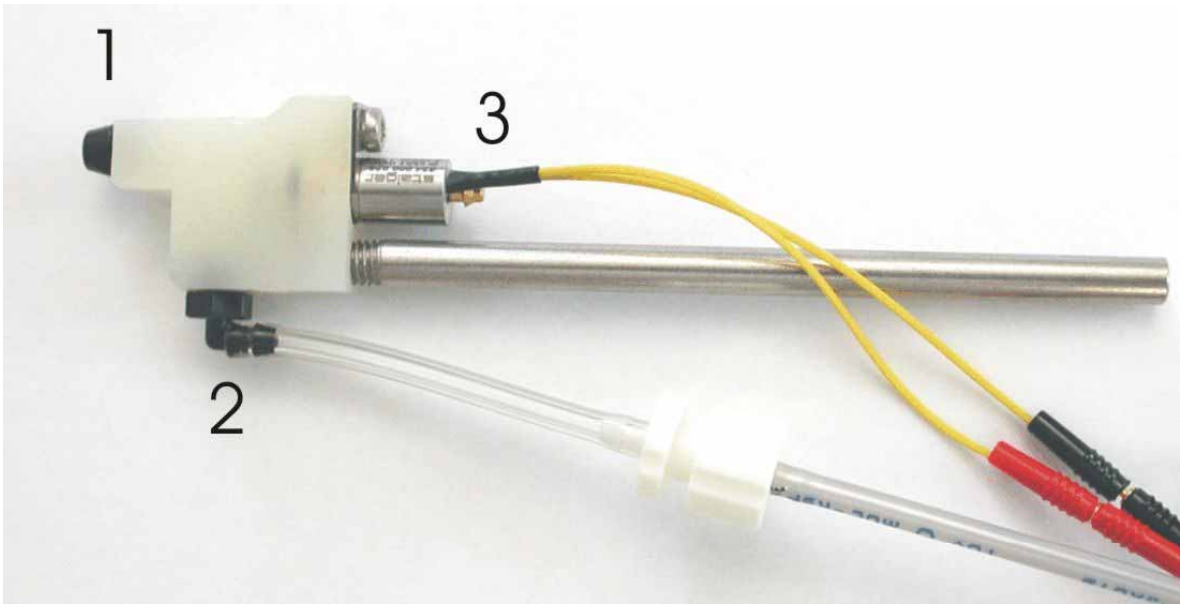

Figure 3: external valve on remote valve plate

- 1: electrical connection
- 2: EJECT pressure source tubing
- 3: connector for ejection pipette
- 4: exhaust connector (optional)
- 5: GND connector for grounding the valve

microJECT micro Valve Pipette Holder

The valve which is controlled by the PEXT-01 is located in the micro valve pipette holder, called *microJECT* (see Figure 4). Tubing and cable of the *microJECT* are connected at the rear panel of the PEXT-01 system (refer to chapter 2.3). Exhaust is usually not connected.

Figure 4: *microJECT*

- 1: pipette connector
- 2: connector for EJECT pressure source
- 3: connector for EXHAUST pressure (optional)

2.5. Headstage (Option)

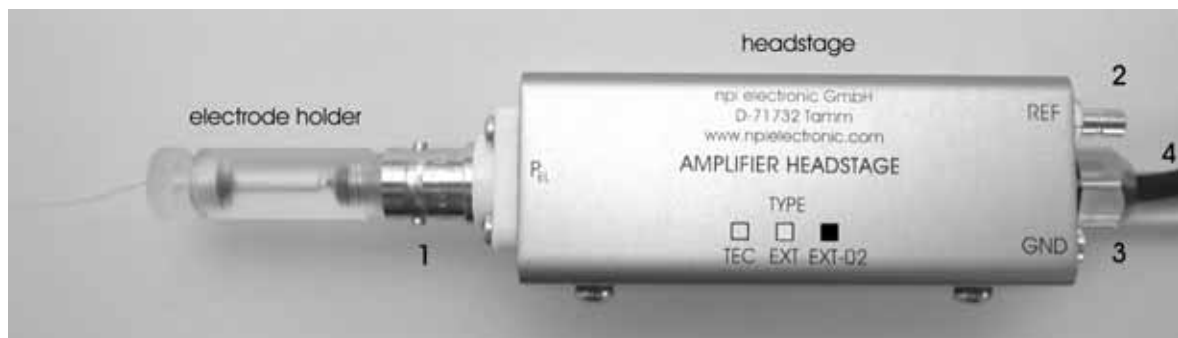

Figure 5: headstage (optional) and electrode holder (optional) and of the PEXT-01

Headstage Elements

- 1 P_{EL} : BNC connector for the electrode holder (measuring electrode)
- 2 REF: connector for the reference electrode
- 3 GND: ground connector
- 4 holding bar

On request, P_{EL} can be implemented using 1 mm or 2 mm banana jacks or using SMC SUBCLIC connectors.

3. Operation

3.1. Pressure Ejection

- ❑ Connect the pressure tubing of the external valve to the OUT connector and the electrical connector to the VALVE connector at the rear panel.
- ❑ Connect your ejection pipettes to the external valve, e.g. using an ejection pipette holder.
- ❑ Turn on pressure and adjust the EJECTION pressure to the desired value using the pressure regulator.
- ❑ Connect a digital timing unit to the TTL INPUT BNC connector at the front panel.
- ❑ For remote operation connect the remote control push button (option) to the REMOTE CONTROL connector.
- ❑ Turn channel on (TIMER control).
- ❑ The LED is red when no ejection occurs and green when the pressure is applied to the pipette.
- ❑ Select the operation mode using the respective toggle switch at the front panel (see Figure 1).
 - In the CONT. position the application can be controlled manually, i.e. as long as the CONT. position is set pressure is applied to the pipette.
 - In the EXT. position the duration of the application is determined directly by the duration of the TTL pulse.
 - In the TIMER position the duration is preset by the timer control and time base of the PEXT-01.
- ❑ Use the START button to test the system. The START button can be used to start ejection in TIMER or EXT. mode. In TIMER mode pushing the START button starts ejection for the time set by the timer control. In EXT. mode ejection lasts as long as the START button is pushed.

Note: The minimal pressure that can be applied is 30 mbar.

Note: Green LED indicates that the valve is not connected properly or continuous operation.

Manual mode

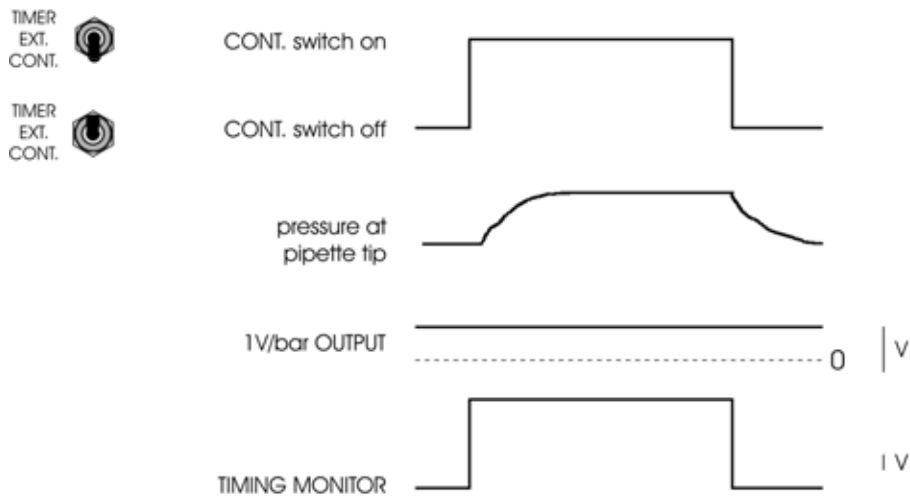

EXTERNAL mode

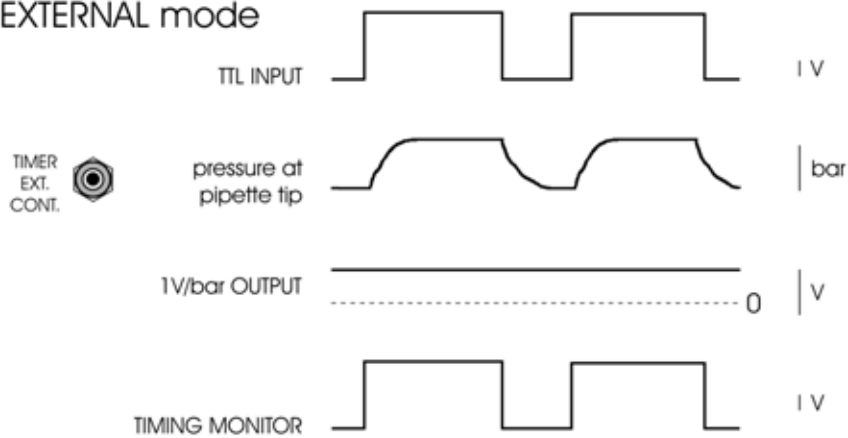

TIMER mode

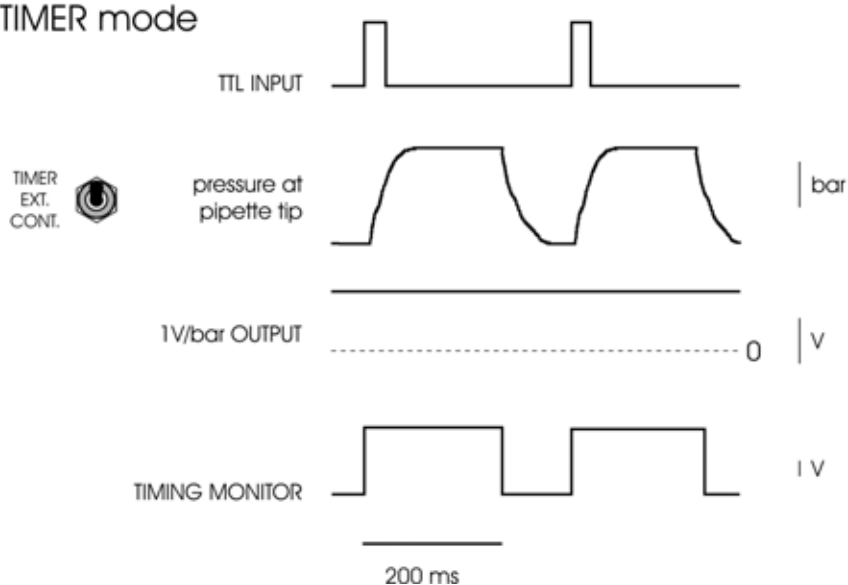

Figure 6: operation modes (pressure ejection) of the PEXT-01

3.2. Extracellular Recording

The EXT amplifier of the PEXT-01 can be operated either using the BNC inputs of the front panel (#30, Figure 1) or using a headstage.

Very Important: You **must not** use inputs at the front panel and a headstage simultaneously!! If the BNC connectors are used the headstage must be disconnected.

Extracellular measurements are mostly done in slices or *in vivo*, where distortions of the signal caused by other instruments and the animal itself are very common. Additionally, extracellular signals are very small and have to be amplified enormously. The drawback is that noise is amplified as well. Therefore, the PEXT-01 is equipped with differential input that minimizes noise pick-up. Differential means, that the signal for the amplifier is the difference between the positive (+) (P_{EL} at the headstage) and negative (-) (REF. at the headstage) input of the amplifier. This results in canceling of all signals which both electrodes record, e.g. noise.

For differential measurements, both inputs are connected to electrodes using cables with grounded enclosure or electrode holders. + (P_{EL}) is connected to the measuring electrode and - (REF.) to the reference electrode. If no headstage is used, the switches #28, Figure 1 have to be in the same position, i.e. both set to ON. The experimental chamber is grounded by an Ag-AgCl pellet (or an AGAR bridge) connected to GND of the headstage (see Figure 7).

Important: If differential measurement is not required (single-ended measurement configuration), the REF input must be connected to ground (GND at the headstage, see Figure 7) or the -IN switch (#28, Figure 1) must be set to OFF.

If no headstage is used, the switch corresponding to the unused INPUT (+ or -) has to be set to OFF (see #28, Figure 1).

The amplifier is in an undefined state, if the REF is left open, and can go into saturation making reliable measurements impossible.

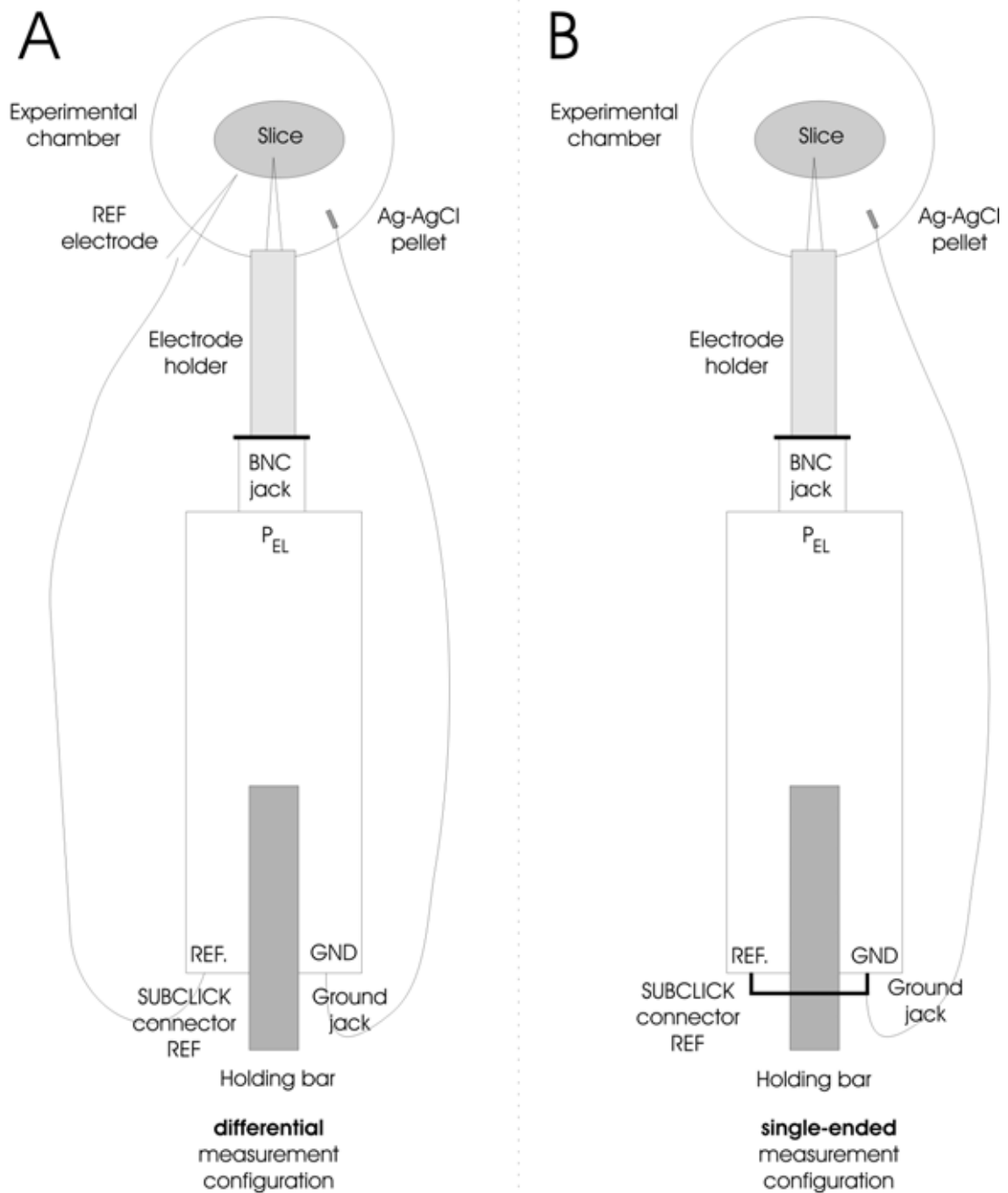

Figure 7: headstage connections, A: differential measurement, B: single-ended measurement

Hint: The REF connector of the headstage can also be set to GND by grounding the -IN connector at the front panel using #28, Figure 1.

4. Literature

4.1. Pressure Ejection

- ❑ Bickmeyer, U., Heine, M., Manzke, T., & Richter, D. W. (2002). Differential modulation of Ih by 5-HT receptors in mouse CA1 hippocampal neurons. *Eur.J.Neurosci.* **16**, 209-218.
- ❑ Guzman, J. N., Hernandez, A., Galarraga, E., Tapia, D., Laville, A., Vergara, R., Aceves, J., & Bargas, J. (2003). Dopaminergic modulation of axon collaterals interconnecting spiny neurons of the rat striatum. *J Neurosci.* **23**, 8931-8940.
- ❑ Hahnel, C. (1992). Quantitative Microinjection, in: H. Kettenmann and R. Grantyn (eds.) *Practical Electrophysiological methods*, Wiley-Liss, New York.
- ❑ Hanganu, I. L. & Luhmann, H. J. (2004). Functional Nicotinic Acetylcholine Receptors on Subplate Neurons in Neonatal Rat Somatosensory Cortex. *Journal of Neurophysiology* **92**, 189-198.
- ❑ Heck, N., Kilb, W., Reiprich, P., Kubota, H., Furukawa, T., Fukuda, A., & Luhmann, H. J. (2006). GABA-A Receptors Regulate Neocortical Neuronal Migration In Vitro and In Vivo. *Cereb Cortex*. doi:10.1093/cercor/bhj135
- ❑ Hofmeier, G & Lux, H. D. (1981). The time course of intracellular free calcium and related electrical effects after injection of CaCl₂ into neurons of the snail *Helix pomatia*, *Pflügers Arch.* **391**, 242-251.
- ❑ **Lalley, P.M. (1999) Microiontophoresis and Pressure Ejection, in: U. Windhorst, and H. Johansson (eds) *Modern Techniques in Neuroscience Research*, Springer, Berlin Heidelberg, New York.**
- ❑ Misgeld, U. (1992). Droplet application of Agonists, in: H. Kettenmann and R. Grantyn (eds.) *Practical Electrophysiological methods*. Wiley-Liss, New York
- ❑ Partridge, L. D., Zeilhofer, H. U. & Swandulla, D. (1998). Combined Whole-Cell and Single-Channel Current Measurement with Quantitative Ca²⁺ Injection or Fura-2 Measurement of Ca²⁺. In P.M. Conn (Ed.) *Ion Channels Part B, Methods in Enzymology* **293**, Academic Press San Diego.
- ❑ Ponimaskin, E., Dumuis, A., Gaven, F., Barthet, G., Heine, M., Glebov, K., Richter, D. W., & Oppermann, M. (2005). Palmitoylation of the 5-Hydroxytryptamine4a Receptor Regulates Receptor Phosphorylation, Desensitization, and {beta}-Arrestin-Mediated Endocytosis. *Molecular Pharmacology* **67**, 1434-1443.
- ❑ Wetzel C. H., Oles, M., Wellerdieck, C., Kuczkowiak, M., Gisselmann, G. and H. Hatt (1999) Specificity and Sensitivity of a Human Olfactory Receptor Functionally Expressed in Human Embryonic Kidney 293 Cells and Xenopus Laevis Oocytes, *J. Neurosci*, 19(17):7426–7433

4.2. Extracellular Recording

- ❑ Barmashenko, G., Eysel, U. T., & Mittmann, T. (2003). Changes in intracellular calcium transients and LTP in the surround of visual cortex lesions in rats. *Brain Res.* **990**, 120-128.
- ❑ Boulton, A. A., Baker, G. B. & Vanderwolf, C. H. (eds.) (1990). *Neurophysiological Techniques, Basic Methods and Concepts*. Humana Press, Clifton, New Jersey.
- ❑ Huemmeke, M., Eysel, U. T., & Mittmann, T. (2002). Metabotropic glutamate receptors mediate expression of LTP in slices of rat visual cortex. *Eur.J.Neurosci.* **15**, 1641-1645.
- ❑ Huemmeke, M., Eysel, U. T., & Mittmann, T. (2004). Lesion-induced enhancement of LTP in rat visual cortex is mediated by NMDA receptors containing the NR2B subunit. *J Physiol* **559** , 875-882.
- ❑ Schulz, D., Huston, J. P., Jezek, K., Haas, H. L., Roth-Harer, A., Selbach, O., & Luhmann, H. J. (2002). Water maze performance, exploratory activity, inhibitory avoidance and hippocampal plasticity in aged superior and inferior learners. *Eur.J.Neurosci.* **16**, 2175-2185.
- ❑ Kettenmann, H. & Grantyn, R. (eds.) (1992). *Practical Electrophysiological Methods*. Wiley-Liss, New York
- ❑ Kowski, A. B., Veh, R. W., & Weiss, T. (2009). Dopaminergic activation excites rat lateral habenular neurons in vivo. *Neuroscience.* **161**, 1154-1165.
- ❑ Lalley, P.M., A.K. Moschovakis and U. Windhorst (1999) Electrical Activity of Individual Neurons In Situ: Extra- and Intracellular Recording, in: U. Windhorst and H. Johansson (eds.) *Modern Techniques in Neuroscience Research*, Springer, Berlin, New York.
- ❑ Lambert, F. M., Beck, J. C., Baker, R., & Straka, H. (2008). Semicircular canal size determines the developmental onset of angular vestibuloocular reflexes in larval *Xenopus*. *Journal of Neuroscience* **28**, 8086-8095.
- ❑ Meuth, S. G., Aller, M. I., Munsch, T., Schuhmacher, T., Seidenbecher, T., Meuth, P., Kleinschnitz, C., Pape, H. C., Wiendl, H., Wisden, W., & Budde, T. (2006). The contribution of TASK-1-containing channels to the function of dorsal lateral geniculate thalamocortical relay neurons. *Molecular Pharmacology*.
- ❑ Müller, Ch.M. (1992) Extra- and Intracellular Recording in the Slice, in: Kettenmann, H. & Grantyn, R. (eds.) *Practical Electro-physiological Methods*, Wiley-Liss, New York
- ❑ Ogden, D. (ed.) (1992) *Microelectrode Techniques - The Plymouth Workshop Handbook*, Second Edition, The Company of Biologists Ltd., Cambridge
- ❑ Schneider, N. L. & Stengl, M. (2006). Gap junctions between accessory medulla neurons appear to synchronize circadian clock cells of the cockroach *Leucophaea maderae*. *J Neurophysiol.* **95**, 1996-2002.
- ❑ Seidenbecher, T. and H.C. Pape (2001) Contribution of intralaminar thalamic nuclei to spike-and-wave-discharges during spontaneous seizures in a genetic rat model of absence epilepsy, *European Journal of Neuroscience*, Vol. 13:1537-1546
- ❑ Windhorst, U. and H. Johansson (eds.) (1999) *Modern Techniques in Neuroscience Research*, Springer, Berlin, Heidelberg, New York

5. Technical Data

Dimensions:

19" rackmount cabinet, 19" (483 mm), 10" (250 mm), 3.5" (88 mm)

Power requirements:

115V / 230V AC, 20-40 W, Fuse: 0.2A / 230V; 0.4 A / 115V

5.1. Pressure Ejection

Source gas:

air, nitrogen, helium etc. no aggressive, combustible or explosive gases, filtered by a 5 µm filter element.

Pressure range:

input pressure: max. 5 bar (1 bar = 10^5 Pa = 14.5 psi)

pressure control range: 0.03-2 bar, 0.44-29 psi or 0.03-4 bar, 0.44-58 psi

Input and output couplings:

quick connect type

Tubes:

input: 6 mm OD

output: 4 mm OD

Status / EJECT time indicator:

red/green LED

red light: channel has been turned on, valve is closed

green light: valve is open or valve not connected

Mode selection:

three position toggle switch, (TIMER, CONT., EXT.)

Minimum valve switch time: 10 ms or <1 ms (*microJECT*)

Digital timer:

100 µs – 9.9999 s set by five digit tumble-wheel switch (0000.0-9999.9)

Pulse input:

standard BNC connector, TTL (LO = 0-2.5 V, HI = 2.5-12 V), input impedance 10 kΩ

Pulse output:

PRESSURE MONITOR: standard BNC connector, sensitivity: 1 V / bar or 0.1 V / psi, output impedance 249 Ω

TIMING MONITOR: standard BNC connector, TTL (LO = +0-1 V, HI = +5 V), output impedance 50 Ω

5.2. *Extracellular Recording*

Input:	$>10^{12} \Omega$, range ± 1 V
Differential Input:	CMR >90 dB at 1 kHz (tested with 0Ω input resistance)
Input Capacitance:	30 pF
OFFSET Compensation:	set by potentiometer, range: ± 0.1 , ± 1 V set by toggle switch
HIGHPASS Filter:	single pole, attenuation: -6 dB / octave, corner frequencies (Hz): 3, 30, 100, 300, 400, 500, 600, 800, 1k, 3k, 10k
LOWPASS Filter:	single pole, attenuation: -6 dB/octave, corner frequencies (Hz): 30, 100, 300, 500, 700, 900, 1.3k, 1.5k, 1.7k, 3k, 10k, 20k
NOTCH Filter (optional):	50 Hz or 60 Hz
GAIN:	rotary-switch 10-20-50-100-200-500-1k-2k-5k-10k
Overload LEDs:	starting to light up at approx. ± 10 V
Output:	range: ± 10 V into $1 \text{ k}\Omega$ / ± 1 V into 50Ω
Potential Monitor:	analog display for the electrode offset, range ± 30 mV

Headstage (optional)

Headstage Size:	70 x 26 x 26 mm
Holding Bar:	length: 150 mm; diameter: 8 mm