

# OPERATING INSTRUCTIONS AND SYSTEM DESCRIPTION FOR THE

## PDES-02DX

# PNEUMATIC DRUG EJECTION SYSTEM

standard with *microJECT*



VERSION 1.2

npi 2011

## Table of Contents

1. Safety Regulations.....	3
2. PDES-2DX System .....	4
2.1. System Description.....	4
2.2. Description of the Front Panel.....	5
2.3. Description of the Rear Panel.....	7
2.4. microJECT micro Valve Pipette Holder.....	8
2.5. Operation .....	8
3. Literature .....	11
General Methods .....	11
General .....	11
Microinjection into Oocytes .....	12
Fast drug application with microJECT (EHM) .....	12
4. Technical Data.....	13

## 1. Safety Regulations

**VERY IMPORTANT:** Instruments and components supplied by npí electronic are **NOT** intended for clinical use or medical purposes (e.g. for diagnosis or treatment of humans), or for any other life-supporting system. npí electronic disclaims any warranties for such purpose. Equipment supplied by npí electronic must be operated only by selected, trained and adequately instructed personnel. For details please consult the **GENERAL TERMS OF DELIVERY AND CONDITIONS OF BUSINESS** of npí electronic, D-71732 Tamm, Germany.

- 1) **GENERAL:** This system is designed for use in scientific laboratories and must be operated by trained staff only. General safety regulations for operating electrical devices should be followed.
- 2) **AC MAINS CONNECTION:** While working with the npí systems, always adhere to the appropriate safety measures for handling electronic devices. Before using any device please read manuals and instructions carefully.  
The device is to be operated only at 115/230 Volt 60/50 Hz AC. Please check for appropriate line voltage before connecting any system to mains.  
Always use a three-wire line cord and a mains power-plug with a protection contact connected to ground (protective earth).  
Before opening the cabinet, unplug the instrument.  
Unplug the instrument when replacing the fuse or changing line voltage. Replace fuse only with an appropriate specified type.
- 3) **STATIC ELECTRICITY:** Electronic equipment is sensitive to static discharges. Some devices such as sensor inputs are equipped with very sensitive FET amplifiers, which can be damaged by electrostatic charge and must therefore be handled with care. Electrostatic discharge can be avoided by touching a grounded metal surface when changing or adjusting sensors. **Always turn power off when adding or removing modules, connecting or disconnecting sensors, headstages or other components from the instrument or 19" cabinet.**
- 4) **TEMPERATURE DRIFT / WARM-UP TIME:** All analog electronic systems are sensitive to temperature changes. Therefore, all electronic instruments containing analog circuits should be used only in a warmed-up condition (i.e. after internal temperature has reached steady-state values). In most cases a warm-up period of 20-30 minutes is sufficient.
- 5) **HANDLING:** Please protect the device from moisture, heat, radiation and corrosive chemicals.

**HIGH PRESSURE PRECAUTIONS:** While working with PDES systems and components, always adhere to the appropriate safety measures for handling high pressure pneumatic systems. Before using the PDES or any external pneumatic device please read the manual and instructions carefully.

- Always turn off pressure source before connecting or disconnecting the PDES system.
- Any component used (tubes, fittings etc.) must be specified for the maximum possible pressure.
- Do not use any aggressive, combustible or explosive gases. Only gases such as air, nitrogen, carbon dioxide, helium, etc. are allowed.
- Use only dry, oil free, filtered gases (max. 5 µm filter is allowed).
- Maximum input pressure must be below 5 bar (1 bar = 100,000 Pa). npí recommends an input pressure of 1 bar more than the maximum output pressure.

## 2. PDES-2DX System

### 2.1. System Description

Pressure ejection is a convenient method for applying both ionic and non-ionic solutions from micropipettes. This method is popular for two reasons. First, it can apply to almost all solutions. Second, the amount of solution ejected can be monitored by viewing the tip of the micropipette under a microscope.

The PDES-2DX is designed for pressure ejection of drugs in physiological and pharmacological studies. PDES systems are equipped with high pressure outputs ( $P_{\max} = 2 \text{ bar} / 29 \text{ psi}$  or  $4 \text{ bar} / 58 \text{ psi}$ ) for drug application with fine-tipped micropipettes, but can also be operated in low-range pressure for controlled droplet application from large-tipped pipettes. Digital timers and a remote control unit facilitate the use of these instruments.

In order to speed up drug ejection, PDES-2DX systems are available with the *microJect* option. These systems are equipped with a micro valve located in an injection holder. The micro valve has a switch time of less than 1 ms and a very small volume that has to be controlled, resulting in application times in the ms range.

The PDES-2DX is housed in a 19" cabinet that can be mounted in a rack. It comprises of two channels. Two systems can be combined to form a 4 channel system. Each channel consists of a precision pressure regulator, a digital pressure display, electronically controlled valves, control electronics and a regulated power supply. Ejection of drugs can be activated manually or via a TTL input. The operational status is indicated by a red/green LED. The pressure output is monitored at a BNC output (1V / bar) and additionally the signal for pressure control is available via TTL OUT BNC connector. Optionally, each channel can be equipped with an "EXHAUST" coupling whereby a low "retain" pressure can be applied (analogous to the "retaining" current used in iontophoretic systems).

Mode of operation and timing is selected by controls at the front panel. If the internal timers are used, the eject time is preset by a control. Each channel can be turned off by using a switch that is combined with the timing control. The operational status is indicated by a red/green LED. Red means that the channel has been turned on and the valve is closed, green indicates that the valve is open and injection takes place.

The remote control unit (option) is housed in a small box. For each channel it has a red LED that indicates if the respective channel is turned on and a toggle switch with a temporary and a fix position for starting drug application.

The pressure connectors (quick connect type) are located at the rear panel of the instrument. Each channel is equipped with an INPUT coupling where the pressure source is connected, an OUTPUT coupling where the injection pipette is connected, and optionally, an EXHAUST coupling where a low "hold" pressure can be applied in order to avoid capillary effects at the tip of the injection pipette or to apply a "retain" negative pressure (analogous to the "retaining" current used in iontophoretic systems). The "retain" pressure must be generated by an additional pneumatic device. Please contact npi electronic for details.

The injection pressure is preset by a precision pressure regulator. The pressure is displayed on a digital manometer. Additional pneumatic devices (tubes, fittings connectors, filters etc.) are available. Please contact npi electronic for details.

A calibration procedure allowing quantitative drug application is described by Hofmeier and Lux (1981) (see chapter 3).

**2.2. Description of the Front Panel**

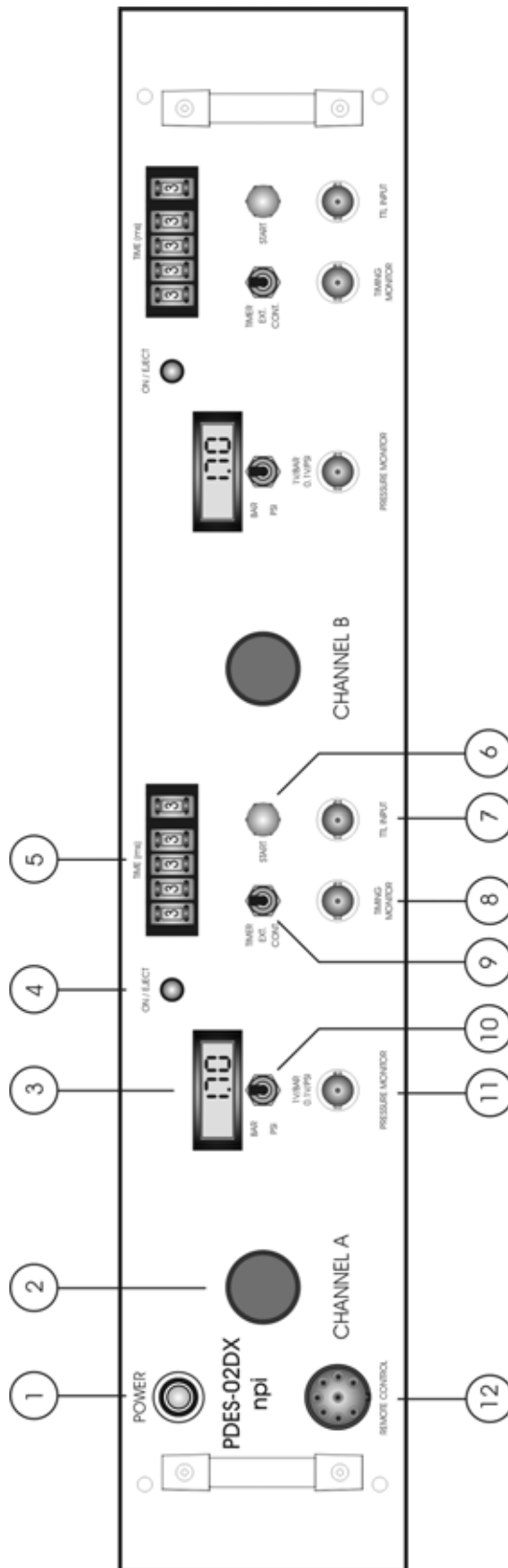

Figure 1: PDES-2DX front panel view (the numbers are related to those in the text below)

In the following description of the front panel elements, each element has a number that is related to that in Figure 1. The number is followed by the name (in uppercase letters) written on the front panel and the type of the element (in lowercase letters). Then, a short description of the element is given. Since the front panel elements are identical for each channel (with identical functions and labels) and therefore, are numbered and described only once (for channel A).

**(1) POWER** push button

Push button to turn POWER on or off

**(2) Pressure regulator**

Rotary knob for regulating the pressure

**(3) Manometer**

Digital display for the pressure (X.XX bar or XXX.X psi)

**(4) ON / EJECT LED**

Indicates the operational status

red light: channel has been turned on, valve is closed

green light: valve is open or valve not connected

**(5) TIME (ms)** tumble-wheel switch

Five digit tumble-wheel switch to set the ejection time (XXXX.X ms) in TIMER mode

**(6) START** button

Push button to start operation. The START button can be used to start ejection in TIMER or EXT. mode.

In TIMER mode pressing the START button opens the valve for the time set by #5.

In EXT. mode pressing the START button opens the valve as long as the button is pressed

**(7) TTL INPUT** connector

BNC connector for external operation

In TIMER mode a TTL HI (+5V) signal opens the valve for the time set by #5.

In EXT. mode a TTL HI (+5V) signal opens the valve as long as the signal level is HI

**(8) TIMING MONITOR** connector

BNC connector providing a TTL signal that indicates the status of the regulated injection valve (HI = valve open, LO = valve closed)

**(9) TIMER A, EXT., CONT.** switch

Switch to set the operation mode (see also chapter 2.4)

**(10) BAR / PSI** switch

Switch to select the unit of the reading of the display (#3) and the output at PRESSURE MONITOR (#11)

**(11) PRESSURE MONITOR** connector

BNC connector monitoring the pressure output, sensitivity: 1 V / bar or 0.1 V / psi, respectively

**(12) REMOTE CONTROL** connector

Connector for the REMOTE CONTROL unit (see Figure 4)

### 2.3. Description of the Rear Panel

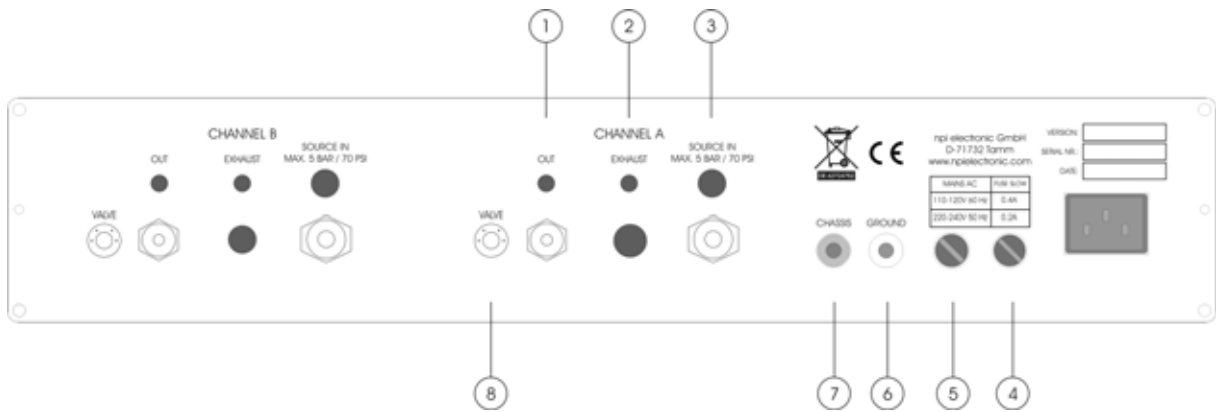

Figure 2: PDES-2DX rear panel view (the numbers are related to those in the text below)

The following connectors are located at the rear panel. The connectors are mentioned only for CHANNEL A.

**(1) OUT connector**

Connector for connecting the micro valve pipette holder, *microJECT*. The EJECT pressure is supplied to this connector.

**(2) EXHAUST connector**

Not installed.

**(3) SOURCE IN connector**

Connector for connecting the filtered, dry and oil-free gas source (5 bar max.).

**Note:** npi recommends an input pressure of 1 bar more than the maximum output pressure.

**(4) FUSE**

Unplug the instrument when replacing the fuse or changing line voltage. Turn knob to open. Replace fuse only with an appropriate specified type (see chapter 0)

**(5) Voltage SELECTOR**

Rotary switch for selecting the operating voltage (115 V / 230 V).

**Caution:** Always switch to the appropriate voltage before connecting the PDES to power.

**(6) GROUND**

This connector is linked to the internal system ground which has no connection to the 19" cabinet (CHASSIS) and the mains ground to avoid ground loops.

**(7) CHASSIS**

This connector is linked to mains ground (green / yellow wire, protective earth).

**(8) VALVE connector**

Connector for the electrical connection of the VALVE located in a remote valve box or in the *microJECT*.

**Important:** This connector is **not** used for systems without a remote valve or *microJECT*.

## 2.4. *microJECT* micro Valve Pipette Holder

The two valves which are controlled by the PDES-02D are located in the micro valve pipette holders, called *microJECT* (see Figure 3). Tubes and cables of both *microJECT*s are connected at the rear panel of the PDES system (refer to chapter 2.3).

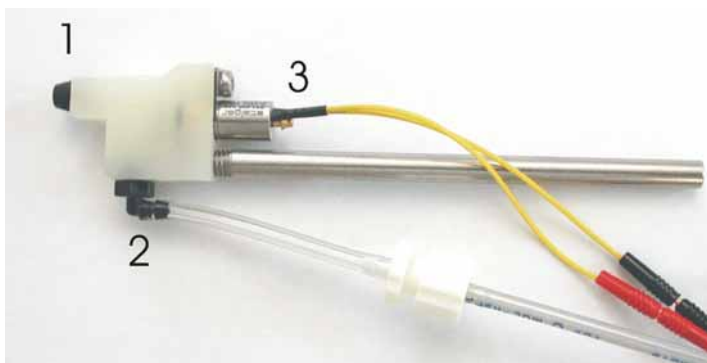

Figure 3: *microJECT*

- 1: pipette connector
- 2: connector for EJECT pressure
- 3: connector for EXHAUST pressure (optional)

## 2.5. Operation

- Connect the gas source to the SOURCE IN connector at the rear panel. The gas source must be clean and filtered by a 5  $\mu\text{m}$  filter element.

**Important:** Do not connect sources of OXYGEN or COMBUSTIBLE or EXPLOSIVE gases!!

- Connect the *microJECT* holders to the OUT connectors and VALVE connectors at the rear panel.
- Connect your ejection pipettes to the *microJECT*s (#1, Figure 3).
- Turn on pressure and adjust the EJECTION pressure to the desired value using the pressure regulator.
- Connect a digital timing unit to the TTL INPUT BNC connector at the front panel.
- For remote operation connect the remote control unit (option) to the REMOTE CONTROL connector.
- Turn channel on (TIMER control).
- The LED is red when no ejection happens, and green when the pressure is applied to the pipette.

- ❑ Select the operation mode using the respective toggle switch at the front panel (see Figure 1).
  - In the CONT. position the application can be controlled manually, i.e. as long as the CONT. position is set pressure is applied to the pipette.
  - In the EXT. position the duration of the application is determined directly by the duration of the TTL pulse.
  - In the TIMER position the duration is preset by the timer control and time base of the PDES.
- ❑ Use the START button to test the system. The START button can be used to start ejection in TIMER or EXT. mode. In TIMER mode pushing the START button starts ejection for the time set by the timer control (#5, Figure 1). In EXT. mode ejection lasts as long as the START button is pushed.
- ❑ REMOTE CONTROL (option): The selected operation mode (at the controller) determines the way the REMOTE CONTROL works.
  - In the CONT. mode the remote control unit is disabled.
  - In the EXTERN mode the valve is open as long the REMOTE control switch is activated (CONT./TIMED = continuous, START = temporarily).
  - In the TIMER mode the internal timer is triggered once by activation of the REMOTE control switch (CONT./TIMED or START). The green LED indicates which channel has been turned on.



Figure 4: PDES remote control

**Note:** Green LED indicates that the valve is not connected properly or continuous operation.

### Manual mode

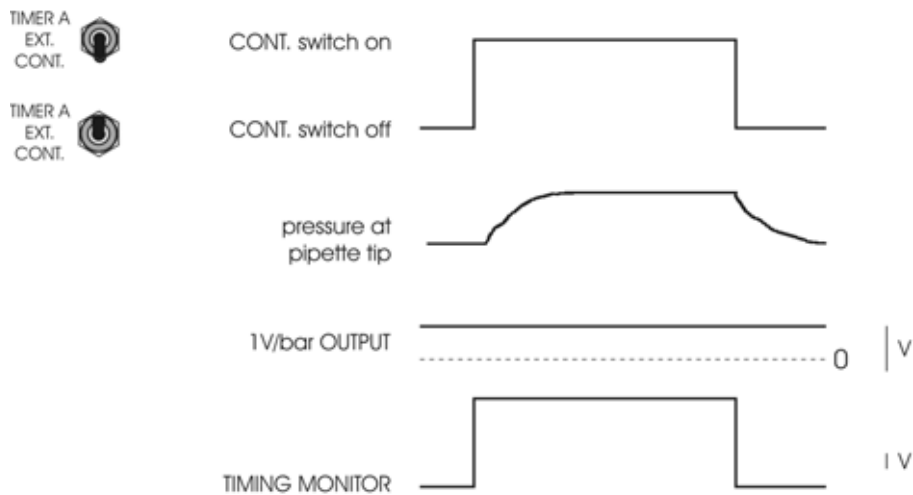

### EXTERNAL mode

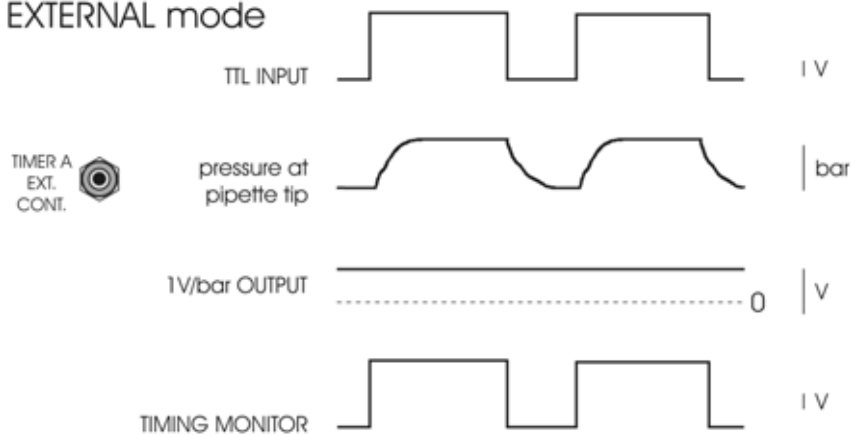

### TIMER mode

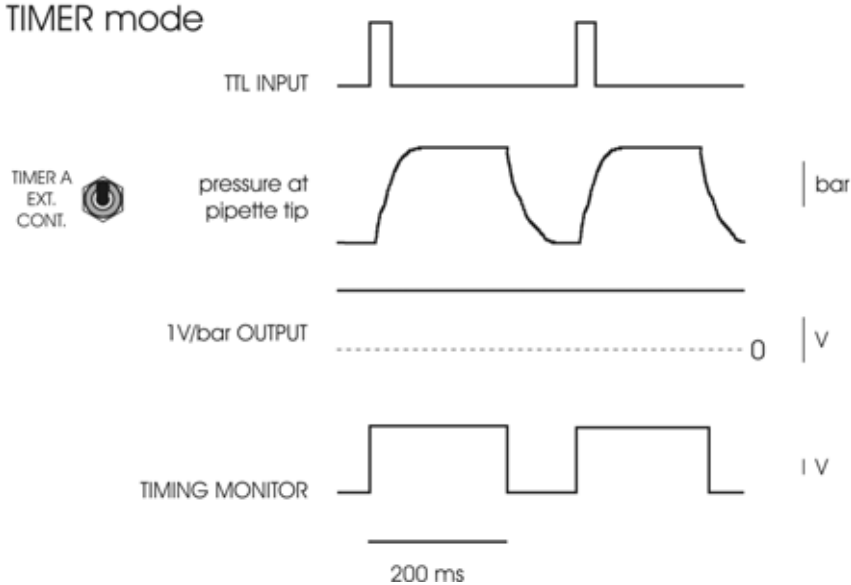

if the internal timer is set to 200 ms

Figure 5: operation modes of the PDES-2DX

### 3. Literature

#### *General Methods*

- ❑ Hahnel, C. (1992) Quantitative Microinjection, in: H. Kettenmann and R. Grantyn (eds.) Practical Electrophysiological methods, Wiley-Liss, New York
- ❑ Hofmeier G, Lux HD (1981) The time course of intracellular free calcium and related electrical effects after injection of CaCl<sub>2</sub> into neurons of the snail, *Helix pomatia* Pflügers Arch. 391:242-251
- ❑ Lalley, P.M. (1999) Microiontophoresis and Pressure Ejection, in: U. Windhorst, and H. Johansson (eds) Modern Techniques in Neuroscience Research, Springer, Berlin Heidelberg, New York
- ❑ Misgeld, U (1992) Droplet application of Agonists, in: H. Kettenmann and R. Grantyn (eds.) Practical Electrophysiological methods, Wiley-Liss, New York

#### *General*

- ❑ Bickmeyer, U., Heine, M., Manzke, T., & Richter, D. W. (2002). Differential modulation of Ih by 5-HT receptors in mouse CA1 hippocampal neurons. *Eur.J.Neurosci.* **16**, 209-218.
- ❑ Eggermann, E. & Feldmeyer, D. (2009). Cholinergic filtering in the recurrent excitatory microcircuit of cortical layer 4. *Proc.Natl.Acad.Sci.U.S.A.* **106**, 11753-11758.
- ❑ Garaschuk, O., Milos, R. I., & Konnerth, A. (2006). Targeted bulk-loading of fluorescent indicators for two-photon brain imaging in vivo. *Nat.Protocols* **1**, 380-386.
- ❑ Guzman, J. N., Hernandez, A., Galarraga, E., Tapia, D., Laville, A., Vergara, R., Aceves, J., & Bargas, J. (2003). Dopaminergic modulation of axon collaterals interconnecting spiny neurons of the rat striatum. *J Neurosci.* **23**, 8931-8940.
- ❑ Hanganu, I. L. & Luhmann, H. J. (2004). Functional Nicotinic Acetylcholine Receptors on Subplate Neurons in Neonatal Rat Somatosensory Cortex. *Journal of Neurophysiology* **92**, 189-198.
- ❑ Kilb, W., Hanganu, I. L., Okabe, A., Sava, B. A., Shimizu-Okabe, C., Fukuda, A., & Luhmann, H. J. (2008). Glycine receptors mediate excitation of subplate neurons in neonatal rat cerebral cortex. *J.Neurophysiol.* **100**, 698-707.
- ❑ Kolbaev, S. & Draguhn, A. (2008). Glutamine-induced membrane currents in cultured rat hippocampal neurons. *Eur.J Neurosci.* **28**, 535-545.
- ❑ Langer, J. & Rose, C. R. (2009). Synaptically induced sodium signals in hippocampal astrocytes in situ. *J Physiol.* **587**, 5859-5877.
- ❑ Lin, B. J., Chen, T. W., & Schild, D. (2007). Cell type-specific relationships between spiking and [Ca<sup>2+</sup>]<sub>i</sub> in neurons of the *Xenopus* tadpole olfactory bulb. *Journal of Physiology* **582**, 163-175.
- ❑ Marandi, N., Konnerth, A., & Garaschuk, O. (2002). Two-photon chloride imaging in neurons of brain slices. *Pflugers Arch.* **445**, 357-365.
- ❑ Partridge, L.D., H.U. Zeilhofer and D. Swandulla (1998) Combined Whole-Cell and Single-Channel Current Measurement with Quantitative Ca<sup>2+</sup> Injection or Fura-2 Measurement of Ca<sup>2+</sup>, in P.M. Conn (Ed.) Ion Channels Part B, Methods in Enzymology Vol. 293, Academic Press SanDiego.

- ❑ Ponimaskin, E., Dumuis, A., Gaven, F., Barthet, G., Heine, M., Glebov, K., Richter, D. W., & Oppermann, M. (2005). Palmitoylation of the 5-Hydroxytryptamine<sub>4</sub> Receptor Regulates Receptor Phosphorylation, Desensitization, and  $\beta$ -Arrestin-Mediated Endocytosis. *Molecular Pharmacology* **67**, 1434-1443.
- ❑ Qiu, J., Yao, S., Hindmarch, C., Antunes, V., Paton, J., & Murphy, D. (2007). Transcription factor expression in the hypothalamo-neurohypophyseal system of the dehydrated rat: upregulation of gonadotrophin inducible transcription factor 1 mRNA is mediated by cAMP-dependent protein kinase A. *J Neurosci.* **27**, 2196-2203.
- ❑ Stepanyan, R. & Frolenkov, G. I. (2009). Fast adaptation and Ca<sup>2+</sup> sensitivity of the mechanotransducer require myosin-XVa in inner but not outer cochlear hair cells. *Journal of Neuroscience* **29**, 4023-4034.
- ❑ Wolfram, V. & Juusola, M. (2004). The Impact of Rearing Conditions and Short-Term Light Exposure on Signaling Performance in Drosophila Photoreceptors. *Journal of Neurophysiology* **92**, 1918-1927.

#### *Microinjection into Oocytes*

- ❑ Wetzel, C. H., Oles, M., Wellerdieck, C., Kuczkowiak, M., Gisselmann, G., & Hatt, H. (1999). Specificity and sensitivity of a human olfactory receptor functionally expressed in human embryonic kidney 293 cells and *Xenopus Laevis* oocytes. *J.Neurosci.* **19**, 7426-7433.

#### *Fast drug application with microJECT (EHM)*

- ❑ Courjaret, R., Troger, M., & Deitmer, J. W. (2009). Suppression of GABA input by A1 adenosine receptor activation in rat cerebellar granule cells. *Neuroscience.* **162**, 946-958.
- ❑ Heck, N., Kilb, W., Reiprich, P., Kubota, H., Furukawa, T., Fukuda, A., & Luhmann, H. J. (2007). GABA-A receptors regulate neocortical neuronal migration in vitro and in vivo. *Cereb Cortex.* **17**, 138-148.

## 4. Technical Data

### Source gas:

air, nitrogen, helium etc. no aggressive, combustible or explosive gases, filtered by a 5  $\mu\text{m}$  filter element.

### Pressure range:

input pressure: max. 5 bar (1 bar =  $10^5$  Pa = 14.5 psi)  
pressure control range: 0-2 bar, 0-29 psi or 0-4 bar, 0-58 psi

### Input and output couplings:

quick connect type

### Tubes:

input: 6 mm OD  
output: 4 mm OD

### Status / EJECT time indicator:

red/green LED

red light: channel has been turned on, valve is closed

green light: valve is open or valve not connected

### Mode selection:

three position toggle switch, (TIMER, CONT., EXT.)

### Minimum valve switch time: <1 ms

### Digital timer:

100  $\mu\text{s}$  – 9.9 s set by five digit tumble-wheel switch (0000.0-9999.9)

### Pulse input:

standard BNC connector, TTL (LO = 0-2.5 V, HI = 2.5-12 V), input impedance 10 k $\Omega$

### Pulse output:

PRESSURE MONITOR: standard BNC connector, sensitivity: 1 V / bar or 0.1 V / psi, output impedance 249  $\Omega$

TIMING MONITOR: standard BNC connector, TTL (LO = +0-1 V, HI = +5 V), output impedance 249  $\Omega$

### Dimensions:

19" rackmount cabinet, 19" (483 mm), 10" (250 mm), 3.5" (88 mm)

### Power requirements:

115/230 V AC, 20-40 W, Fuse: 0.2A / 230V; 0.4 A / 115V

### Remote control (option):

Toggle switch and status LED for each channel, size 2.5x4x10 cm