

OPERATING INSTRUCTIONS AND SYSTEM DESCRIPTION FOR THE

EXT-T2

8-CHANNEL EXTRACELLULAR AMPLIFIER SYSTEM FOR 2 TETRODES



VERSION 1.1
npi 2010

npi electronic GmbH, Hauptstrasse 96, D-71732 Tamm, Germany
Phone +49 (0)7141-9730230; Fax: +49 (0)7141-9730240
support@npielectronic.com; <http://www.npielectronic.com>

Table of Contents

1. Safety Regulations	3
2. EXT-T2 Amplifier / Filter	4
2.1. System Description.....	4
2.2. Description of the Front Panel.....	4
2.3. Description of the Rear Panel.....	6
3. Headstage.....	7
4. Technical Data	7

1. Safety Regulations

VERY IMPORTANT: Instruments and components supplied by npi electronic are NOT intended for clinical use or medical purposes (e.g. for diagnosis or treatment of humans), or for any other life-supporting system. npi electronic disclaims any warranties for such purpose. Equipment supplied by npi electronic must be operated only by selected, trained and adequately instructed personnel. For details please consult the GENERAL TERMS OF DELIVERY AND CONDITIONS OF BUSINESS of npi electronic, D-71732 Tamm, Germany.

- 1) **GENERAL:** This system is designed for use in scientific laboratories and must be operated by trained staff only. General safety regulations for operating electrical devices should be followed.
- 2) **AC MAINS CONNECTION:** While working with the npi systems, always adhere to the appropriate safety measures for handling electronic devices. Before using any device please read manuals and instructions carefully.
The device is to be operated only at 115/230 Volt 60/50 Hz AC. Please check for appropriate line voltage before connecting any system to mains.
Always use a three-wire line cord and a mains power-plug with a protection contact connected to ground (protective earth).
Before opening the cabinet, unplug the instrument.
Unplug the instrument when replacing the fuse or changing line voltage. Replace fuse only with an appropriate specified type.
- 3) **STATIC ELECTRICITY:** Electronic equipment is sensitive to static discharges. Some devices such as sensor inputs are equipped with very sensitive FET amplifiers, which can be damaged by electrostatic charge and must therefore be handled with care. Electrostatic discharge can be avoided by touching a grounded metal surface when changing or adjusting sensors. **Always turn power off when adding or removing modules, connecting or disconnecting sensors, headstages or other components from the instrument or 19" cabinet.**
- 4) **TEMPERATURE DRIFT / WARM-UP TIME:** All analog electronic systems are sensitive to temperature changes. Therefore, all electronic instruments containing analog circuits should be used only in a warmed-up condition (i.e. after internal temperature has reached steady-state values). In most cases a warm-up period of 20-30 minutes is sufficient.
- 5) **HANDLING:** Please protect the device from moisture, heat, radiation and corrosive chemicals.

2. EXT-T2 Amplifier / Filter

2.1. System Description

The EXT-T2 instrument is an amplifier/filter with headstages for two tetrodes, A and B. The signals recorded from every single tetrode attached to the headstages are amplified and filtered, and linked to the BNC connectors OUTPUT 0 to OUTPUT 3 for every tetrode. Each OUTPUT is available at two BNC connectors. The GROUND plug provides system ground. Measurements are done in single-ended configuration against GND.

2.2. Description of the Front Panel

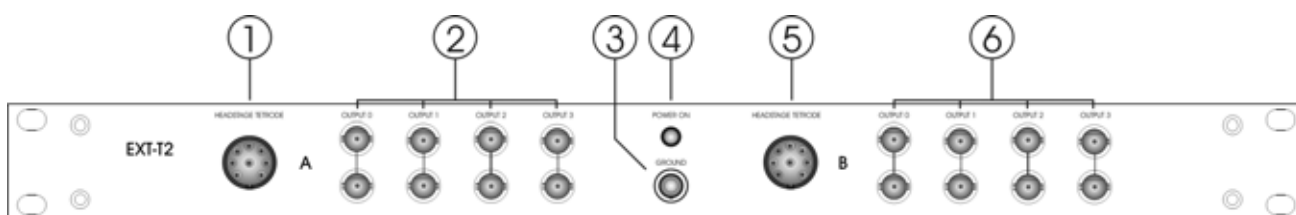

Figure 1: front panel view of EXT-T2

- (1) HEADSTAGE connector
Connector for the HEADSTAGE of TETRODE A
- (2) OUTPUT 0...OUTPUT 3 connectors
BNC connectors providing the amplified and filtered signals of tetrode A
- (3) GROUND connector
Banana jack providing system ground
- (4) POWER ON LED
LED indicating that POWER is switched ON
- (5) HEADSTAGE connector
Connector for the HEADSTAGE of TETRODE B
- (6) OUTPUT 0...OUTPUT 3 connectors
BNC connectors providing the amplified and filtered signals of tetrode B.

Each channel has a single PCB with amplifier and filters. Amplification factors (200, 500; 1000) and corner frequencies of high pass (0.1, 0.3, 1 Hz) filter and low pass (500, 2k, 8k Hz) filter can be set internally at the PCB by DIL switches and a jumper (see also Table 1 and Table 2) for each channel separately.

Jumper	S1	S2	S3	S4	S5	S6	Setting
							(Amplification / Filtering)
ON	ON	ON	OFF	ON	OFF	OFF	DC, gain 200, LP 8 kHz
ON	ON	ON	ON	ON	OFF	OFF	DC, gain 500, LP 8 kHz
ON	ON	ON	ON	OFF	OFF	OFF	DC, gain 1000, LP 8 kHz
ON	ON	ON	OFF	ON	ON	OFF	DC, gain 200, LP 2 kHz
ON	ON	ON	ON	ON	ON	OFF	DC, gain 500, LP 2 kHz
ON	ON	ON	ON	OFF	ON	OFF	DC, gain 1000, LP 2 kHz
ON	ON	ON	OFF	ON	ON	ON	DC, gain 200, LP 500 Hz
ON	ON	ON	ON	ON	ON	ON	DC, gain 500, LP 500 Hz
ON	ON	ON	ON	OFF	OFF	ON	DC, gain 1000, LP 500 Hz

Table 1: DC recordings

Jumper	S1	S2	S3	S4	S5	S6	Setting
OFF	ON	ON	OFF	ON	OFF	OFF	HP 0,1 Hz, gain 200, LP 8 kHz
OFF	ON	ON	ON	ON	OFF	OFF	HP 0,1 Hz, gain 500, LP 8 kHz
OFF	ON	ON	ON	OFF	OFF	OFF	HP 0,1 Hz, gain 1000, LP 8 kHz
OFF	ON	ON	OFF	ON	ON	OFF	HP 0,1 Hz, gain 200, LP 2 kHz
OFF	ON	ON	ON	ON	ON	OFF	HP 0,1 Hz, gain 500, LP 2 kHz
OFF	ON	ON	ON	OFF	ON	OFF	HP 0,1 Hz, gain 1000, LP 2 kHz
OFF	ON	ON	OFF	ON	ON	ON	HP 0,1 Hz, gain 200, LP 500 Hz
OFF	ON	ON	ON	ON	ON	ON	HP 0,1 Hz, gain 500, LP 500 Hz
OFF	ON	ON	ON	OFF	OFF	ON	HP 0,1 Hz, gain 1000, LP 500 Hz
OFF	OFF	ON	OFF	ON	OFF	OFF	HP 0,3 Hz, gain 200, LP 8 kHz
OFF	OFF	ON	ON	ON	OFF	OFF	HP 0,3 Hz, gain 500, LP 8 kHz
OFF	OFF	ON	ON	OFF	OFF	OFF	HP 0,3 Hz, gain 1000, LP 8 kHz
OFF	OFF	ON	OFF	ON	ON	OFF	HP 0,3 Hz, gain 200, LP 2 kHz
OFF	OFF	ON	ON	ON	ON	OFF	HP 0,3 Hz, gain 500, LP 2 kHz
OFF	OFF	ON	ON	OFF	ON	OFF	HP 0,3 Hz, gain 1000, LP 2 kHz
OFF	OFF	ON	OFF	ON	ON	ON	HP 0,3 Hz, gain 200, LP 500 Hz
OFF	OFF	ON	ON	ON	ON	ON	HP 0,3 Hz, gain 500, LP 500 Hz
OFF	OFF	ON	ON	OFF	OFF	ON	HP 0,3 Hz, gain 1000, LP 500 Hz
OFF	ON	ON	OFF	ON	OFF	OFF	HP 1 Hz, gain 200, LP 8 kHz
OFF	ON	ON	ON	ON	OFF	OFF	HP 1 Hz, gain 500, LP 8 kHz
OFF	ON	ON	ON	OFF	OFF	OFF	HP 1 Hz, gain 1000, LP 8 kHz
OFF	ON	ON	OFF	ON	ON	OFF	HP 1 Hz, gain 200, LP 2 kHz
OFF	ON	ON	ON	ON	ON	OFF	HP 1 Hz, gain 500, LP 2 kHz
OFF	ON	ON	ON	OFF	ON	OFF	HP 1 Hz, gain 1000, LP 2 kHz
OFF	ON	ON	OFF	ON	ON	ON	HP 1 Hz, gain 200, LP 500 Hz
OFF	ON	ON	ON	ON	ON	ON	HP 1 Hz, gain 500, LP 500 Hz
OFF	ON	ON	ON	OFF	OFF	ON	HP 1 Hz, gain 1000, LP 500 Hz

Table 2: AC recordings

Gain: amplification factor
 HP: corner frequency high pass filter
 LP: corner frequency low pass filter

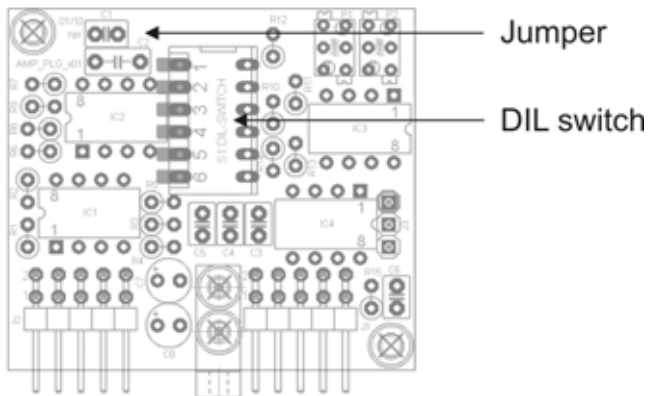

Figure 2: PCB of one amplifier, location of DIL switch and jumper

2.3. Description of the Rear Panel

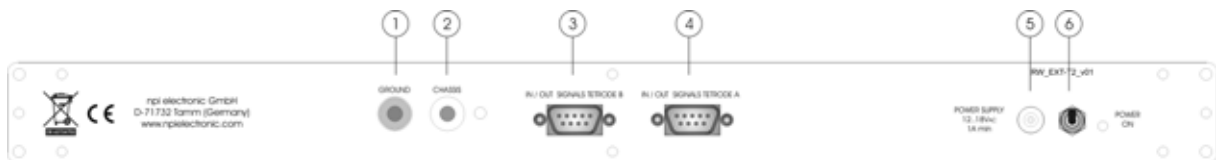

Figure 3: rear panel view of EXT-T2

(1) GROUND

This connector is linked to the internal system ground which has no connection to the 19" cabinet (CHASSIS) to avoid ground loops

(2) CHASSIS

This connector is not linked to system ground and can be used for grounding the CHASSIS independently from system ground

(3) IN / OUT SIGNALS TETRODE B

Not connected

(4) IN / OUT SIGNALS TETRODE A

Not connected

(5) POWER SUPPLY connector

Connector for the wall POWER SUPPLY (12V...18V AC, 1A min.)

(6) POWER ON switch

Switch to turn POWER ON (upper position).

3. Headstage



Figure 4: one headstage of the EXT-T2

Headstage Elements

P_{EL} Connector for the tetrode (see also Figure 5)

REF Not connected

GND Ground connector



- 1** Ground connector (GND)
- 2** Channel 1 connector (CH0)
- 3** Channel 3 connector (CH2)
- 4** Channel 4 connector (CH3)
- 5** Channel 2 connector (CH1)

Figure 5: tetrode connector

4. Technical Data

Input resistance: $>10^{12} \Omega$, range $\pm 1 \text{ V}$

Output: gain (x200, x500, x1000), selectable by DIL switch
Output range: $\pm 12 \text{ V}$ into $1 \text{ k}\Omega$ / $\pm 1 \text{ V}$ into 50Ω load

Low pass filter: 500, 2k, 8k Hz, selectable by DIL switch

High pass filter: DC, 0.1, 0.3, 1, selectable by DIL switch

Power requirements: 12...18 V AC, 1 A min.; wall power supply

Dimensions: 19" rackmount cabinet, 19" (483 mm), 10" (250 mm), 1.75" (44 mm)

Headstage Size: 70 x 26 x 26 mm

Holding Bar: length: 150 mm; diameter: 8 mm.